

Mirage 4K25



User Manual

020-101361-02

Mirage 4K25

User Manual

020-101361-02

NOTICES

COPYRIGHT AND TRADEMARKS

Copyright ©2015 Christie Digital Systems USA Inc. All rights reserved.

All brand names and product names are trademarks, registered trademarks or trade names of their respective holders.

GENERAL

Every effort has been made to ensure accuracy, however in some cases changes in the products or availability could occur which may not be reflected in this document. Christie reserves the right to make changes to specifications at any time without notice. Performance specifications are typical, but may vary depending on conditions beyond Christie's control such as maintenance of the product in proper working conditions. Performance specifications are based on information available at the time of printing. Christie makes no warranty of any kind with regard to this material, including, but not limited to, implied warranties of fitness for a particular purpose. Christie will not be liable for errors contained herein or for incidental or consequential damages in connection with the performance or use of this material. Canadian manufacturing facility is ISO 9001 and 14001 certified.

WARRANTY

Products are warranted under Christie's standard limited warranty, the complete details of which are available by contacting your Christie dealer or Christie. In addition to the other limitations that may be specified in Christie's standard limited warranty and, to the extent relevant or applicable to your product, the warranty does not cover:

- a. Problems or damage occurring during shipment, in either direction.
- b. Projector lamps (See Christie's separate lamp program policy).
- c. Problems or damage caused by use of a projector lamp beyond the recommended lamp life, or use of a lamp other than a Christie lamp supplied by Christie or an authorized distributor of Christie lamps.
- d. Problems or damage caused by combination of a product with non-Christie equipment, such as distribution systems, cameras, DVD players, etc., or use of a product with any non-Christie interface device.
- e. Problems or damage caused by the use of any lamp, replacement part or component purchased or obtained from an unauthorized distributor of Christie lamps, replacement parts or components including, without limitation, any distributor offering Christie lamps, replacement parts or components through the internet (confirmation of authorized distributors may be obtained from Christie).
- f. Problems or damage caused by misuse, improper power source, accident, fire, flood, lightning, earthquake or other natural disaster.
- g. Problems or damage caused by improper installation/alignment, or by equipment modification, if by other than Christie service personnel or a Christie authorized repair service provider.
- h. Problems or damage caused by use of a product on a motion platform or other movable device where such product has not been designed, modified or approved by Christie for such use.
- i. Problems or damage caused by use of a projector in the presence of an oil-based fog machine or laser-based lighting that is unrelated to the projector.
- j. For LCD projectors, the warranty period specified in the warranty applies only where the LCD projector is in "normal use" which means the LCD projector is not used more than 8 hours a day, 5 days a week.
- k. Except where the product is designed for outdoor use, problems or damage caused by use of the product outdoors unless such product is protected from precipitation or other adverse weather or environmental conditions and the ambient temperature is within the recommended ambient temperature set forth in the specifications for such product.
- l. Image retention on LCD flat panels.
- m. Defects caused by normal wear and tear or otherwise due to normal aging of a product.

The warranty does not apply to any product where the serial number has been removed or obliterated. The warranty also does not apply to any product sold by a reseller to an end user outside of the country where the reseller is located unless (i) Christie has an office in the country where the end user is located or (ii) the required international warranty fee has been paid.

The warranty does not obligate Christie to provide any on site warranty service at the product site location.

PREVENTATIVE MAINTENANCE

Preventative maintenance is an important part of the continued and proper operation of your product. Please see the Maintenance section for specific maintenance items as they relate to your product. Failure to perform maintenance as required, and in accordance with the maintenance schedule specified by Christie, will void the warranty.

REGULATORY

The product has been tested and found to comply with the limits for a Class A digital device, pursuant to Part 15 of the FCC Rules. These limits are designed to provide reasonable protection against harmful interference when the product is operated in a commercial environment. The product generates, uses, and can radiate radio frequency energy and, if not installed and used in accordance with the instruction manual, may cause harmful interference to radio communications. Operation of the product in a residential area is likely to cause harmful interference in which case the user will be required to correct the interference at the user's own expense.

CAN ICES-3 (A) / NMB-3 (A)

이 기기는 업무용 (A 급) 으로 전자파적합등록을 한 기기이오니 판매자 또는 사용자는 이점을 주의하시기 바라며, 가정 외의 지역에서 사용하는 것을 목적으로 합니다.

Environmental

The product is designed and manufactured with high-quality materials and components that can be recycled and reused. This symbol  means that electrical and electronic equipment, at their end-of-life, should be disposed of separately from regular waste. Please dispose of the product appropriately and according to local regulations. In the European Union, there are separate collection systems for used electrical and electronic products. Please help us to conserve the environment we live in!

Addendum

Translated copies of this document are provided on the CD in the back of this document. The CD may also contain additional product documentation. Read all instructions before using or servicing this product.

本文档的翻译副本在本文档背面的 CD 上提供。该 CD 中还可能包含其他产品文档。使用或维修本产品之前请务必阅读所有说明。

文件背面的光碟提供了本文件的翻譯副本。這張光碟可能另外包含其他產品文件。請先閱讀所有指示再使用或送修本產品。

Le CD au dos de ce document contient des traductions de celui-ci dans différentes langues. Ce CD peut également contenir de la documentation supplémentaire sur le produit. Lisez toutes les instructions avant d'utiliser ou d'entretenir ce produit.

Übersetzte Versionen dieses Dokuments werden auf der CD auf dem Vorsatzblatt dieses Dokuments bereitgestellt. Die CD kann auch zusätzliche Produktdokumentation enthalten. Bitte lesen Sie diese Anweisungen vor der Verwendung dieses Produkts oder vor der Ausführung von Wartungsarbeiten am Produkt.

Le copie tradotte di questo documento sono fornite sul CD, sul retro di questo documento. Il CD potrebbe anche contenere altra documentazione sul prodotto. Si prega di leggere tutte le istruzioni prima di utilizzare questo prodotto o sottoporlo a manutenzione.

このドキュメントの翻訳版がこのドキュメントの裏面の CD で提供されています。CD には追加の製品マニュアルも収められています。この製品を使用したり、機能させたりする前に、すべての指示をお読みください。

이 문서의 번역된 사본이 이 문서 후면의 CD 에서 제공됩니다. 이 CD 에는 추가 제품 설명서가 포함되어 있을 수 있습니다. 이 제품을 사용하거나 수리하기 전에 모든 지침을 확인하십시오.

Copias traduzidas deste documento são fornecida no CD contido na parte de trás deste documento. O CD pode conter documentação adicional do produto. Leia todas as instruções antes de usar ou prestar serviço com este produto.

Перевод данного документа представлен на компакт-диске на оборотной стороне документа. Компакт-диск может также содержать дополнительную документацию по продукту. Перед использованием или обслуживанием продукта ознакомьтесь со всеми инструкциями.

Las copias traducidas de este documento se proporcionan en el CD que se encuentra en la parte trasera. En el CD también puede encontrar documentación adicional del producto. Lea todas las instrucciones antes de utilizar o realizar el mantenimiento de este producto.

Перекладені екземпляри цього документа містяться на компакт-диску, який додано до цього документа. На компакт-диску може також бути додаткова документація до виробу. Перш ніж користуватися виробом або його обслуговувати, прочитайте всі інструкції.

Content

- Introduction 14**
 - Safety and warning guidelines 14
 - Installation safety and warning guidelines 15
 - AC/power precautions 15
 - Lamp precautions 16
 - Product safety labels 17
 - Projector overview 18
 - Contact your dealer 18
 - Key features 19
 - How the projector works 20
 - List of components 20

- Installation and Setup 21**
 - Site requirements 21
 - Physical operating environment 21
 - External exhaust ducting 21
 - Power connection 21
 - Tools required for installation 21
 - Projector components 23
 - Position the projector 24
 - Connect to AC power 25
 - Adjust the projector tilt and level 27
 - Install the foot extension rods 27
 - Install the touch panel controller 28
 - Remove the projector shroud 29
 - Set up the lens 30
 - Portrait mode 31
 - 3D setup for Mirage projectors 31
 - 3D requirements 32
 - Active stereo 3D configuration 33
 - Passive stereo 3D configuration 34
 - 3D system timing 34
 - 3D input video configurations 35
 - Set up a single Mirage 4K to display 3D content 35

Confirm the emitter setup 35

Configure the projector for the 3D source 36

Connect Devices 37

 Input video mapping 37

 Four-Port: 3GIC, TDPIC, THIC cards 37

 Four-Port: DDIC card 38

 Two-Port: TDPIC card 38

 Two-Port: DDIC card 38

 Connect a video source using DisplayPort 39

 Connect a video source using 3G Input card 39

 Connect a video source using HDMI 40

 Connect a video source using DVI 41

 Select a video source 41

 Connect devices to the 3D Sync ports 42

 Connect a computer or server 42

 Set up the ethernet 43

Adjust the Image 44

 Select screen image orientation 44

 Maximize light output 44

 Align the image 44

 Adjust offset 45

 Adjust horizontal boresight 45

 Adjust vertical boresight 46

 Lock the lens offsets 48

 Adjust DMD convergence 49

 Color correction 49

 Adjust color by temperature 49

 Adjust color by precise chromaticity values 50

 Adjust color by saturation 50

 Adjust the fold mirror 50

Operation 52

 Projector LED status indicators 52

 Turn the projector on 52

 LED expected behavior on power up 53

 Turn the projector off 53

 Work with lamps 53

Adjust lamp power	53
Adjust the lamp position with LampLOC	54
Calibrate the lamp	54
Manually adjust the lamp position	54
View lamp information	54
Track lamp intensity with LiteLoc	55
Lamp details	55
Record new lamp information	55
Add lamp end-of-life indicator	55
Work with lenses	56
Select a channel	56
Enable warping and blending	57
Send error notifications to specified devices	57
Menus	58
Touch panel controller	58
Tab structure	59
Menu tab details	61
Status tab details	61
Backup, Restore, and Upgrade Projector Files	63
Upgrade the projector software	63
Back up projector settings	63
Export backup settings to an external device	64
Restore settings from a local backup profile	64
Restore default settings	64
Import file from an external device to restore settings	64
Maintenance	66
Maintenance shutdown	66
Ventilation and cooling	67
Inspect and clean the airflow interlocks	67
Inspect and clean the exhaust duct	67
Inspect and clean the lamp blower	67
Inspect and fill the coolant reservoir	68
Remove the liquid cooling reservoir	68
Filtration	70
Replace the light engine air filter	70
Replace the liquid cooling air filter	70

Replace the laminar airflow device filter	71
Lamps	71
Adjust the yoke assembly	72
Inspect and clean the lamp	72
Remove dust from the projection lens	73
Remove fingerprints, smudges, or oil from the projection lens	74
Remove the projection lens	74
Install the projection lens	74
Calibrate the lens motors	75
Reset lens to home position	75
Troubleshooting	76
Projector does not power on	76
Lamp does not ignite	76
Lamp suddenly turns off	76
Flicker, shadows or dimness	77
LampLOC not working	77
Touch panel controller is blank	77
Blank screen, no display of image	77
Cannot communicate with projector	78
Inaccurate display colors	78
Display is not rectangular	78
Display has suddenly frozen	78
Display is jittery or unstable	78
Incoming signal(s) problems	78
Touch panel controller or projector head problems on startup	79
The Projector LEDs or the MCPU board power LED are not on	79
The MCPU board power LED is not on	79
MCPU board power LED behavior	79
Touch panel controller does not connect	80
3D synchronization problems	80
Left and right eye are reversed	80
Frame multiplication applied to incoming video signals when not required	80
Run the projector interrogator	81
Save TPC log files	81
Specification	82
Display	82
Mirage signal connectivity	84

Optional Input cards	87
Control signal compatibility	87
Temperature sensor thresholds	88
Warning thresholds for fans	89
Warning threshold for liquid cooling module	89
Touch panel controller	89
Power requirements	90
Lamp	90
Physical specifications	90
Regulatory	91
Safety	91
Approvals	91
Electro-magnetic compatibility	91
Environment	92
Accessories	92

Introduction

This manual is intended for professionally trained operators of Christie high-brightness projection systems. These operators are qualified to replace the lamp and air filters, but should not attempt to install or service the projector.

Only accredited Christie technicians who are knowledgeable about the hazards associated with high-voltage, ultraviolet exposure, and the high temperatures generated by the projector lamp are authorized to assemble, install, and service the projector.

For complete Mirage 4K25 product documentation and technical support, go to www.christiedigital.com.

Safety and warning guidelines

This projector must be operated in an environment that meets the operating range specification. Use only the attachments and/or accessories recommended by Christie. Use of others may result in the risk of fire, shock, or personal injury.



Warning! Failure to comply with the following could result in death or serious injury.

- Never look directly into the projector lens or at the lamp. The extremely high brightness can cause permanent eye damage. For protection from ultraviolet radiation, keep all projector housings intact during operation. Protective safety gear and safety goggles are recommended when servicing.
- FIRE HAZARD! Keep hands, clothes, and all combustible material away from the concentrated light beam of the lamp.



Caution! Failure to comply with the following could result in minor or moderate injury.

- Position all cables where they cannot contact hot surfaces or be pulled or tripped over.
- The American Conference of Governmental Industrial Hygienists (ACGIH) recommends occupational UV exposure for an 8-hour day to be less than 0.1 microwatts per square centimeters of effective UV radiation. A workplace evaluation is advised to assure employees are not exposed to cumulative radiation levels exceeding the government guidelines for your area. Be aware that some medications are known to increase sensitivity to UV radiation.

NOTE: During maintenance and cleaning operations, the instructions define that the unit must not be operational, thus the lamps are not active and there are no emissions. Optical adjustments are not considered maintenance. The lamps are turned on during optical adjustments and emissions are present.

Installation safety and warning guidelines



Danger! Failure to comply with the following results in death or serious injury.

- This product must be installed within a restricted access location which is normally inaccessible by the general public, including workers, visitors, and residents in the immediate vicinity, by means of engineering or administrative control measures but is accessible to authorized personnel that may not have specific safety training.
- This product must be located and positioned in a way as to restrict audience members from direct access to enter the light beam path.
- Do not install the projector overhead.
- When installing the projector in portrait mode, the device holding the projector must have a weight rating sufficient to hold the weight of the projector. The projector weighs 125kg (275 lbs).
- The projector uses a high-pressure lamp that may explode if improperly handled. Always wear manufacturer approved protective safety clothing (gloves, jacket, face shield) when the lamp door is open or when handling the lamp. Failure to comply results in death or serious injury.



Warning! Failure to comply with the following could result in death or serious injury.

- A qualified technician is required for all installations.
- SHOCK HAZARD. Never operate the projector without all of its covers in place.
- Use of the projector's rear safety strap is **mandatory** to prevent the projector from tipping. Secure the strap between the projector and the surface it is mounted to.
- Four or more people are required to safely lift and hand-carry one projection head a short distance. Christie recommends removing the lamp before transporting the projector.
- Two or more people are required to safely lift and hand-carry the lamp power supply (LPS).



Notice. Failure to comply with the following may result in property damage.

- Perform an automatic LampLOC adjustment when the lamp is moved, leveled, or a new lamp is installed in the projector.
- Keep the projector level when lifting or transporting. Avoid tilting the projector to the right. This can introduce an air bubble into the coolant hoses that can result in an air lock and the overheating of the projector.

AC/power precautions

To correctly install this projector, a certified electrician must install a permanent three-phase connection to the lamp power supply (LPS). The LPS projector outlet is used to supply power to the projector head. Operate the projector at the recommended voltage.



Danger! Failure to comply with the following results in death or serious injury.

Disconnect projector from AC before opening any enclosure.



Warning! Failure to comply with the following could result in death or serious injury.

- Verify that the projector is using a line cord, socket, and power plug that meets the appropriate local rating standards. Use only an AC power cord recommended by Christie. Do not attempt operation if the AC supply and cord are not within the specified voltage and power range.
- Do **not** allow anything to rest on the power cord. Locate the projector where the cord cannot be abused by persons walking on it or objects rolling over it. Never operate the projector if the power cable appears damaged in any way.
- Do **not** overload power outlets and extension cords as this can result in fire or shock hazards.

Lamp precautions

Lamps used in the projector are under high pressure and must be handled with caution. Lamps can explode and cause serious personal injury if dropped or mishandled.



Danger! Failure to comply with the following results in death or serious injury.

- Never attempt to access the lamp compartment while the lamp is on. Wait at least 10 minutes after the lamp turns off before powering down, disconnecting from AC, and opening the lamp door.
- The arc lamp operates at a high pressure that increases with temperature. Failure to allow the lamp to sufficiently cool before handling, increases the potential for an explosion causing personal injury or property damage.
- Always wear manufacturer approved protective safety clothing (gloves, jacket, face shield) when the lamp door is open or when handling the lamp. Only qualified technicians should install projector lamps.



Warning! Failure to comply with the following could result in death or serious injury.

- Possibly hazardous optical radiation emitted from this product. (Risk group 3)
- Thermal radiation emitted from this product may cause burns. (Risk group 3)



Recommended protective clothing includes, but may not be limited to a polycarbonate face shield, protective gloves, and a quilted ballistic nylon jacket or a welder's jacket. This equipment is included in included in the Christie Protective Clothing Safety kit
P/N: 598900-095.

Christie's protective clothing recommendations are subject to change. Any local or federal specifications take precedence over Christie recommendations.

Product safety labels



Indicates the presence of a grounding point.



Indicates the presence of an earth grounding point.



Indicates the presence of a dangerous condition or situation.



Indicates the presence of a pinch hazard. To avoid personal injury, keep hands clear and loose clothing tied back.



Indicates the presence of a hot surface. To avoid personal injury, always allow the projector to cool down for a minimum of 10 minutes before performing maintenance or service procedures.



Indicates the presence of a hot surface. To avoid personal injury, always allow the projector to cool down for a minimum of 10 minutes before performing maintenance or service procedures.



Indicates the presence of an electrical shock hazard. To avoid personal injury, always disconnect all power sources before performing maintenance or service procedures.



Indicates the presence of an electrocution hazard. To avoid personal injury, always disconnect all power sources before performing maintenance or service procedures.



Indicates the presence of moving fan blades. To avoid personal injury, keep hands clear and loose clothing tied back. Always disconnect all power sources before performing maintenance or service procedures.



Indicates exposure to bright light. To avoid personal injury, never look directly at the light source.



Indicates the presence of an explosion hazard. To avoid personal injury, always disconnect all power sources and wear Christie approved protective clothing.



Indicates the presence of a fire hazard. To avoid personal injury and property damage, always adhere to the instructions described in this manual.

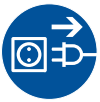

Always disconnect all power sources before performing maintenance or service procedures.



See the product user manual for specific information and directions.



See the product service manual for specific information and directions.



Never look directly into the projector lens. The extremely high brightness can cause permanent eye damage.

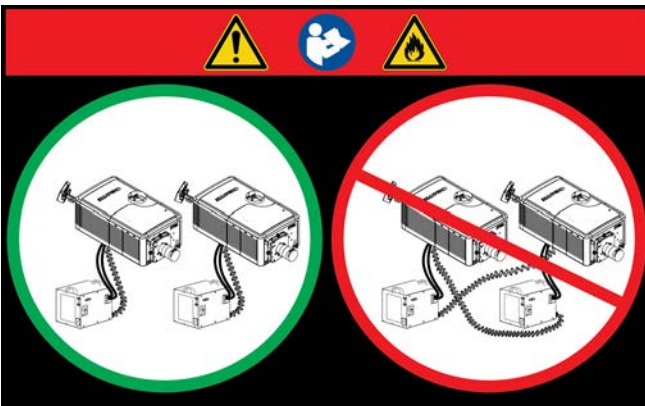

This label warns of a cross-connection hazard when installing multiple projectors at once. A fire hazard exists if a lamp power supply interlock cable is connected to a different projector than its lamp power cables.

For more information, see [Adjust the projector tilt and level](#) in the *Installation and Setup* chapter

Projector overview

The Mirage 4K25 is a professional quality, easy-to-use, split-body projector using Digital Light Processing (DLP™) technology from Texas Instruments. Integrating smoothly into traditional projection environments; the Mirage 4K25 interfaces with local networks throughout the world, for multimedia presentations from a variety of formats, to offer stunning wide screen, high-resolution 4K images at 120 frames per second.

Contact your dealer

If you encounter a problem with your Christie projector, contact your dealer. To assist with the servicing of your projector, enter the information in the tables below and keep this information with your records.

Purchase Record

Dealer:

Dealer or Christie Sales/Service contact phone number:

Purchase Record

Projector serial number:

Purchase date:

Installation date:

**The serial number can be found on the license label located on the front panel*

Ethernet Settings

Default gateway

Projector IP address

Subnet mask

Key features

- 3-chip 4K DLP™ light engine
- 4096 x 2160 native pixel format
- 2.0 and 3.0 kW Xenon lamps available
- Display of stereoscopic 3D video
- Warp and blend of projected images
- Supports screens up to approximately 100 feet in width
- Touch panel controller (TPC) for main projector interface. Verify you have the latest software by visiting <http://www.christiedigital.com>
- 1x 10/100BaseT Ethernet port
- RS232 ports for communication
- 4x Option slots accepting a variety of digital video input option cards
- 3D Sync input/output port
- LiteLOC™ feature for constant image brightness
- LampLOC™ feature for motorized three-axis lamp alignment
- Electronically operated “quick” douser
- Motorized lens mount
- LED indicators on the rear corners of the projector for easy-to-read status indication
- Replaceable air filters (no tools required)
- Optional rack mount stand

- Choice of field-interchangeable zoom lenses

Model Name	Part Number
Mirage 4K25	129-012104-XX

How the projector works

The Mirage 4K25 accepts a variety of input signals for projection on front or rear projection screens, typical in commercial or other large screen applications. High-brightness light is generated by a short arc Xenon lamp, then modulated by three Digital Micromirror Device (DMD) panels responding to incoming data streams of digitized red, green and blue color information. As these digital streams flow from the source, light from the responding “on” pixels of each panel is reflected, converged and then projected to the screen through one or more projection lenses, where all pixel reflections are superimposed in sharp full-color images.

List of components

Verify the following components were received with the projector:

- Touch panel controller (TPC)
- Lens plug (required for shipping when lens is not installed to prevent contamination of critical optical components)
- Light engine removal tool
- Convergence tool
- Nylon safety strap with clip (required to secure projector to tabletop or optional rack mount)
- Warranty card
- Shroud
- Access keys
- Web registration form

Installation and Setup

This section explains how to install, connect, and optimize the projector display.

Site requirements

To safely install and operate the projector, the installation location must have restricted access for authorized personal only and meet these minimum requirements.

Physical operating environment

- Maximum Ambient Temperature (operating) 35°C (95°F)
- Minimum Ambient Temperature (operating) 10°C (50°F)

External exhaust ducting

The installation site must provide a minimum of 450 CFM (ft³/min) external exhaust airflow to ensure adequate cooling of the Xenon arc lamp at less than or equal to 25°C (77°F) ambient and less than 3,000 ft (914.4 m) elevation. Above 25°C or 3,000 ft, 600 CFM is required.

For more details, see [Connect external exhaust ducting](#) on page 28.

Power connection

The requirements listed below are applicable for permanently wired installation or power cord connection:

- Terminal block, electrician hard-wired to the projector head.
- Electrical rating: 200 - 240 VAC, 23 A max.
- This product can be connected to an IT power distribution system.

Tools required for installation

- 12" screwdrivers: Phillips #2 (magnetic) and flat
- 19mm and 7/8" wrenches
- Assorted Allen keys (metric)

- Christie approved protective safety clothing if working with the lamp
- Lens cleaning tissue and solution

Projector components

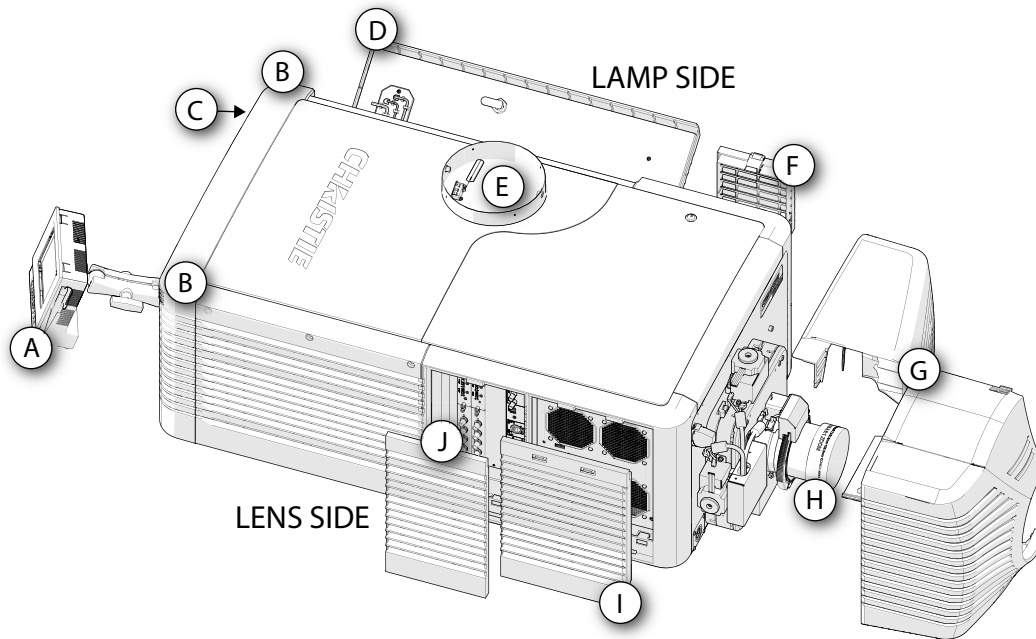

ID	Item	Description
A	Touch panel controller (TPC)	A touch-sensitive screen used to control and monitor operation. For information about TPC controls and settings, see Menus on page 58 .
B	LED status indicators	LED color and blinking rates (located in both back corners of the projector) provide information about the status of the projector. For information about projector states and status, see LED expected behavior on power up on page 53 .
C	Manual douser override	Closing the douser rotates a shutter blade in front of the lamp and reduces the lamp power to 2.0 kW to conserve lamp life. The override is for emergency use only.
D	Lamp door and lamps	The lamp door provides access to the lamp compartment and must remain closed and locked for normal operation. Lamp replacement should only be performed by qualified technicians. For a complete list of available lamp types, see Accessories on page 92 .
E	Exhaust duct and vane switch	Extracts heated air from the lamp compartment. The vane switch mounted inside the rigid port monitors airflow. See Site requirements on page 21 .
F	Liquid cooling air filter Cover and air filter	Filters air before it circulates to cool the heat exchanger. For replacement instructions, see Inspect and clean the lamp on page 72 .
G	Shroud (two-piece)	Covers the motorized lens mount assembly.
H	Projection lens	A variety of lenses can be used with the D4K2560Mirage 4K25. For a list of available lenses, see on page 94
I	Air filter cover and air filter	Filters the intake air before it circulates through the front compartment to cool the main electronics. For replacement instructions, see Inspect and clean the lamp on page 72 .

ID	Item	Description
J	Input panel faceplate	Provides a variety of ports for connecting external devices. For information about connecting devices and inputs, see Connect Devices on page 37.

Position the projector

i Keep the projector lens as perpendicular to the screen as possible, even if significantly above the screen center. When a particularly short throw distance combines with a wide screen, you may have to forfeit some aim and stay more perpendicular to the screen. In such cases, some lens offset can reduce the keystone distortion.

1. Position the projector at an appropriate throw distance (projector-to-screen distance) and vertical position. Ideally, center the projector with the screen. If space is limited, aim the projector slightly off-center. This increases side keystone, but reduces the horizontal lens offset required.

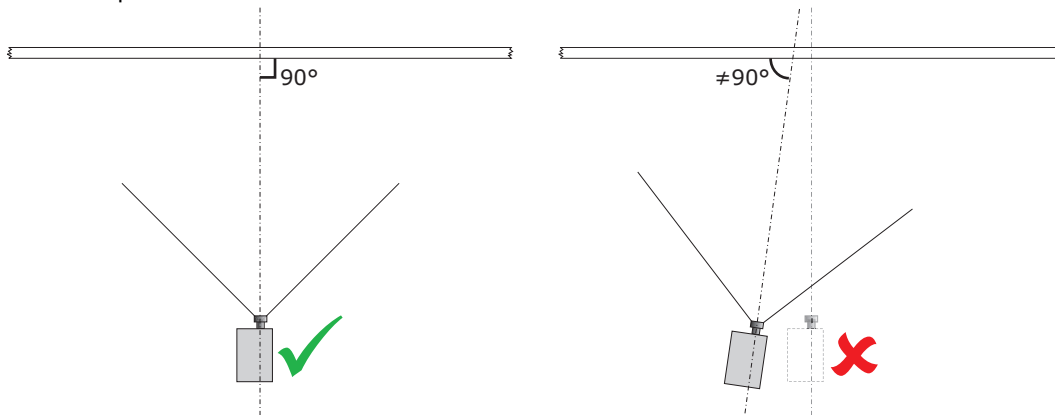

2. If using an optional rack stand (P/N: 108-282101-02), assemble the rack stand using the instructions provided with the rack stand. Use the hold down clamp (P/N: 116-100101-01) when securing the projector to the rack stand.

Connect to AC power



Failure to comply with the following could result in death or serious injury.

- Certified electrician required during installation. Ground (earth) connection is necessary for safety. Never compromise safety by returning the current through the ground. Connect ground first to reduce shock hazard.
- Use an appropriate strain relief connector on the AC supply cable to prevent the cable from rubbing against the LPS knockout plate and becoming damaged.



When connecting the projector directly to AC power, follow all electrical codes for your location. In addition, follow these recommendations:

- Use 10AWG or 8AWG wiring. The distance between the wall circuit breaker and the projector must not exceed 20 meters using 10AWG cables or 30 meters using 8AWG cables.
- For North American installations, use at least 10AWG copper wires for the connection of the main AC supply to the projector's ground lug.
- Copper or aluminum are acceptable as conductor wiring material to the terminal block.



When connecting the projector to AC power with a pluggable type-B cable, follow all electrical codes for your location. In addition, follow these recommendations:

- There must be easy access to the current protection device or breaker in the building.
- Use minimum 10AWG wiring, with a maximum length of 4.5 m for U.S and Canada. For international installations the length should be based on the local electrical codes.
- The socket-outlet is installed near the equipment and is easily accessible.
- The plug can be used as the device disconnect and is near the unit and easily accessible. The circuit breaker on the projector baseplate (located under the front lens-side corner) can also be used as a means of disconnect.

1. On the bottom of the projector in the front lamp-side corner, loosen the two screws and slide the access panel to expose the terminal block.
2. Remove four screws securing the knockout plate to the bottom right corner of the front bezel. Remove the knockout plate. The AC supply is routed to the terminal block through an appropriate strain relief mounted on this knockout plate.

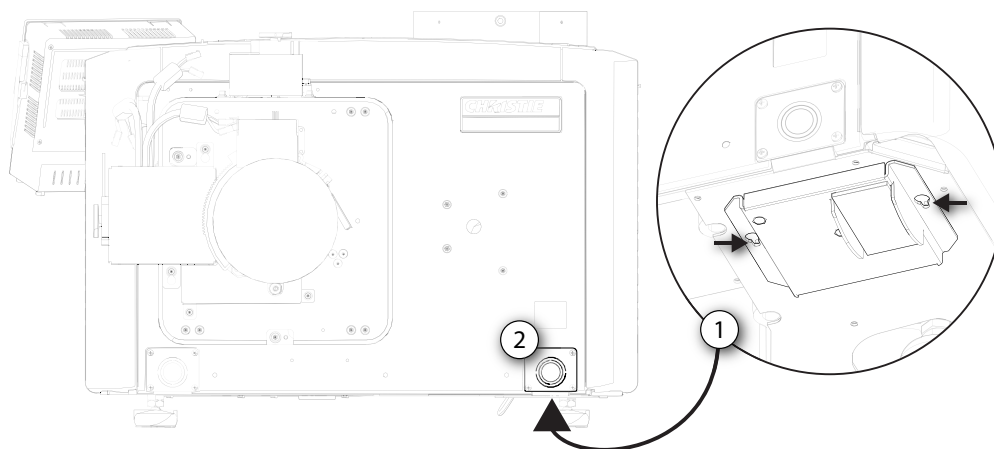

3. Connect to the terminal block.



The terminal block accommodates up to an eight AWG wire. If required, use a 90° strain relief connector to route the power cable in a downward direction.



Always connect the ground lead first to reduce shock hazard.

- If connecting to permanent power, connect the AC power source to the terminal block, beginning with the ground lead.
- If connecting to a pluggable type-B cable, connect the cable to the terminal block, beginning with the ground lead.
- Use an appropriately sized strain relief connector with the knockout plate provided to ensure adequate environmental sealing and to prevent the cables from wear and accidentally being torn out.

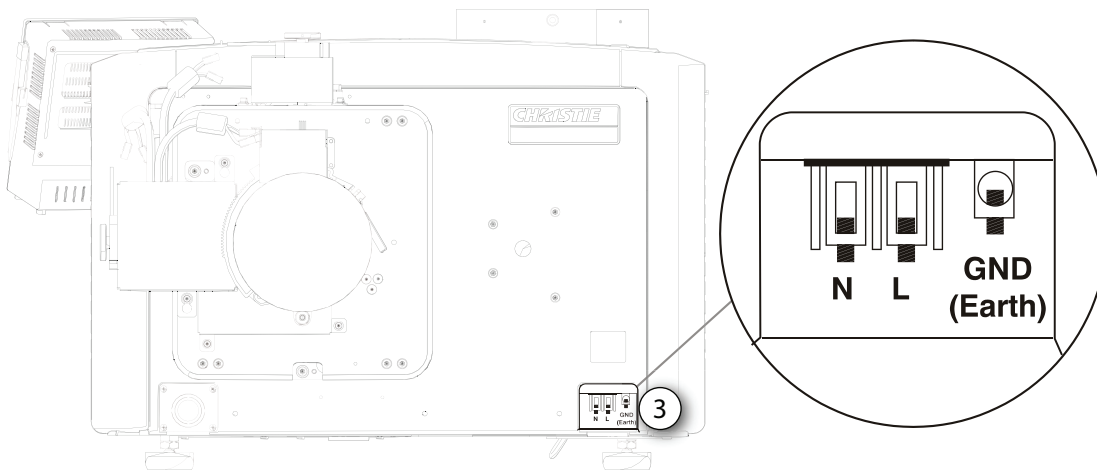
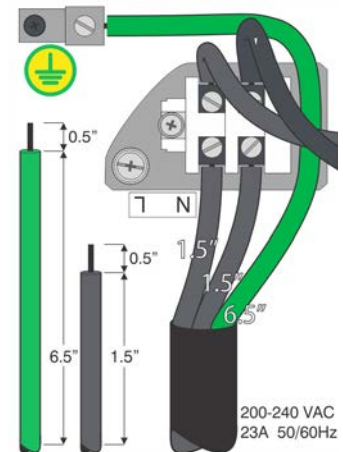

4. Reinstall the knockout plate and secure it with four screws.

5. Reinstall the bottom access panel over the terminal block and secure it with two screws.

If using a pluggable type-B cable, connect to the building's AC power source.

Adjust the projector tilt and level



Warning! Failure to comply with the following could result in death or serious injury.

- The projector's rear safety strap must be in place before adjusting the projector feet.
- Do not over-extend the feet. Make sure several threads are engaged into the projector's baseplate to secure the projector from falling.

Adjust the projector tilt to fill the maximum amount of screen while minimizing keystone. Lens offset can be used to center the image in the center of the screen..



Notice. Failure to comply with the following may result in property damage.

The front-to-back tilt of the projector must not exceed 15 degrees.

1. Secure a safety lifting strap rated to handle the projector weight at the rear of the projector.
2. Hoist up the projector.
3. To adjust the vertical or horizontal position of the projector, extend or retract the adjustable feet on the bottom of the projector (A).
4. Once the required adjustment is made, tighten the lock nut against the bottom of the projector (B).

The projector provides 4 inches of adjustment at the front and 11.5 inches of adjustment at the rear.

5. If the vertical or horizontal position of the projector requires more adjustment than the standard feet allow, two 6-inch extension rods can be installed to increase the amount of available adjustment.

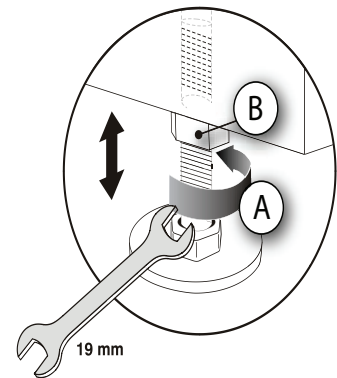

Install the foot extension rods

1. Elevate the rear of the projector to access the two rear feet.
2. Remove the feet by loosening the lock nut and rotating the each foot out of the projector.
3. Add the extension rods to the standard feet.
4. Thread the extended feet into the projector's baseplate.
5. Adjust the feet until the required tilt is achieved.
6. Lock the feet in place by turning each lock nut until it fits tight against the projector.

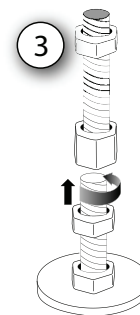
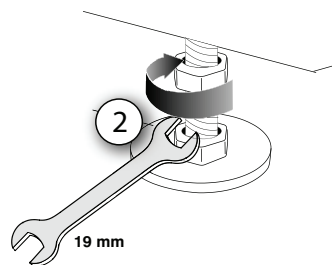
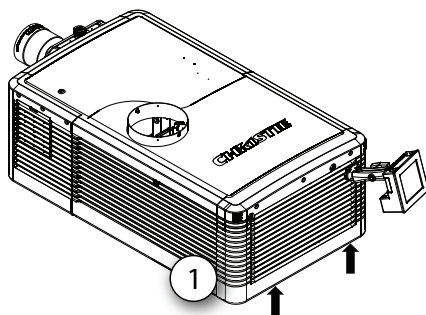

Install the touch panel controller

1. Loosen the mounting arm just enough for the end to fit over the ball joint located on the rear panel of the projector.

The touch panel controller (TPC) becomes loose from the mounting arm when the mounting arm lock is loosened.

2. Tighten the mounting arm lock until it fits tightly on the joint.

The TPC safety strap comes installed on the projector ball point.

3. Connect the cable from the touch panel controller (TPC) to the connector on the rear panel of the projector.

4. Adjust the TPC angle for optimal viewing, then tighten the mounting arm lock securely so that the TPC is held in place at the required location.

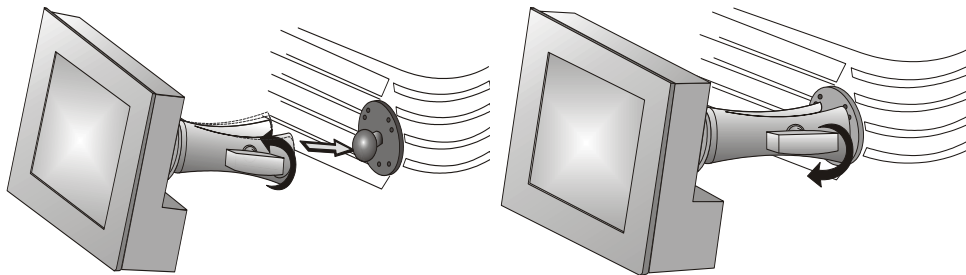

Connect external exhaust ducting



Warning! Failure to comply with the following could result in death or serious injury.

At minimum, a 10-inch (25.4 cm) long, strong metal duct must be installed at the projector and installed to an outside venting duct system to prevent glass shards from exiting the duct in the event of a lamp explosion.



Notice. Failure to comply with the following may result in property damage.

*600 CFM is required in projection rooms with an ambient temperature above 25°C or located at an elevation greater than 3000 feet above sea level.

Connect the existing outside-venting duct to the 8-inch diameter exhaust port on the top of the projector. Make sure there are no obstructions or bends in the ducting or air intakes and the vane switch at the exit duct moves freely.

The pre-installed outside-venting duct should be rigid at the projector and must also include a heat extractor and blower that maintains a minimum of 450 CFM* when the projector is operating at less than or equal to 25°C (77°F) ambient and less than 3,000 feet (914.4 m), when measured at the projector exhaust opening.

To determine the projector exhaust CFM value, use an airflow meter to measure the ft/min at the rigid end of the open exhaust duct that connects to the projector. Take the measurement at the end of the duct without the projector connected.

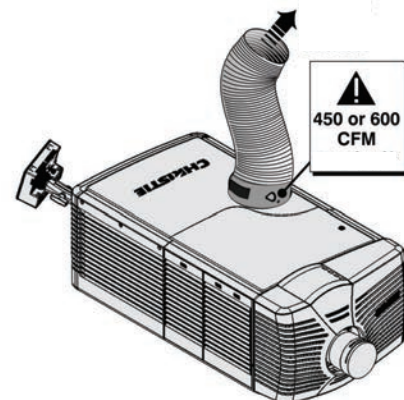

Use this formula to determine the CFM value for the projector: $CFM = 0.35 \times \text{Measured ft/min}$

Lamp Type	Min. Airflow (CFM) Required
2.0 kW	450 CFM*
3.0 kW	450 CFM*

*600 CFM is required in projection rooms with ambient temperature above 25°C (77°F) or elevation (above sea level) greater than 3000 feet (914.4 m).

Add an extractor or a booster if there is insufficient airflow. Do not mount the extractor on the projector as this may introduce some vibration into the image.



Notice. Failure to comply with the following may result in property damage.

Never disable the vane switch. Attempting to operate the projector with inadequate airflow can result in dangerous overheating of the projector.



To prevent the projector from overheating or becoming unsafe, an alarm sounds if the duct is obstructed or a fan fails. Christie recommends regularly verifying that the exhaust is unobstructed and functioning correctly.

Remove the projector shroud



Warning! Failure to comply with the following could result in death or serious injury.

- Never install the shroud for overhead installations.

The lens side shroud must be removed to gain access to the lens. The other shroud must be removed when connecting the AC power cord into the front face of the projector.

1. Use finger pressure to push down on the shroud clips located at the top and bottom of the shroud as shown by the arrows.
2. Carefully slide the shroud sideways and forward away from the lens mount and lens.

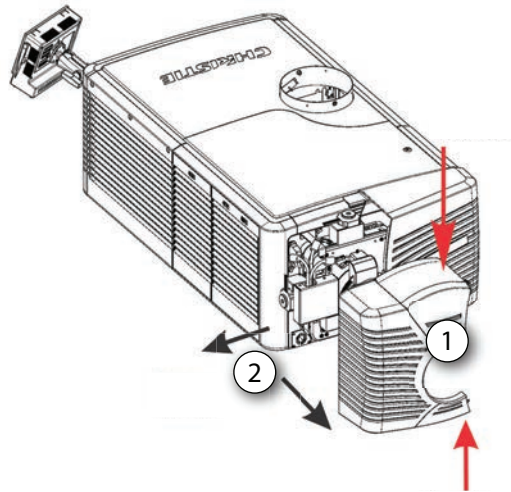

3. Place the shroud covers on a clean surface to prevent scratches.

Set up the lens



Warning! Failure to comply with the following could result in death or serious injury.

- Keep fingers and other body parts away from the moving parts in the projector. Motors and fans may start without warning.
- Tie back long hair, remove jewelry and loose clothing before manually adjusting the projector.
-



Notice. Failure to comply with the following may result in property damage.

The lens seals the projection head, preventing contaminants from entering the main electronics area. Do not operate the projector without a lens installed. Use a lens plug when installing or transporting the projector.

1. Remove the projector shroud.
2. Make sure the lens locking lever is in the up position.
3. If attached, remove the rear lens cap from the lens.
4. Slide the lens into the lens mount, aligning all connections.



Always install the lens with UP label in the top position to achieve consistent boresight alignment each time the lens is replaced.

5. Secure the lens with the lens locking lever (down position).
6. Calibrate the lens motors.

For more details, see [Work with lenses](#) on page 56, [Remove the projector shroud](#) on page 29, and [Calibrate the lens motors](#) on page 75.

Portrait mode

1. Orient the projector in the frame with the lamp door facing downward (as shown).
The maximum tilt angle is ± 15 degrees.

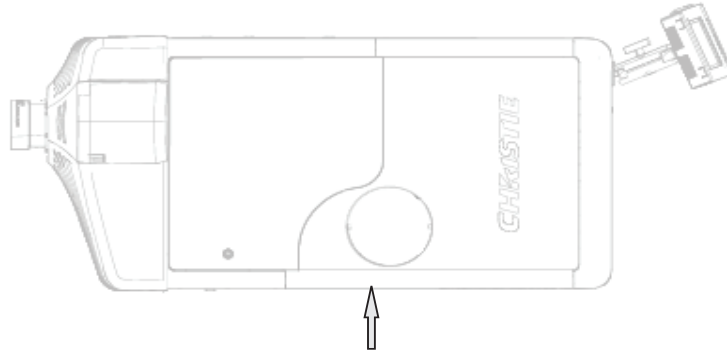

2. Set up the customer-supplied mounting frame.
The mounting frame must be designed to accommodate the weight and mounting provisions of the projector.
3. Remove the projector feet.
4. Attach the projector to the mounting frame using the four M12 holes (normally used for projector feet) on the bottom side of the projector.
Mounting bolts must be grade 8.8 or higher and torqued to 60 ft-lbs.

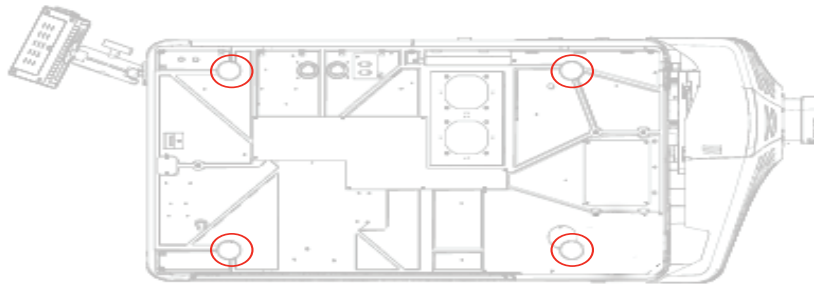

5. Perform a lamp alignment.

3D setup for Mirage projectors

The Mirage projector is capable of displaying stereoscopic 3D video sources, relying on additional hardware (stereo emitters and glasses) to complete the display system.

Images generated from a stereo 3D video source consist of a series of images (frames) that alternate quickly between two slightly different viewpoints, corresponding to our left and right eyes. When these frames are displayed fast enough and viewed with special glasses synchronized to the

left/right (L/R) changes, the resulting image appears with the same depth and perspective sense in the real world.



The type of 3D glasses can be active or passive stereo depending on the type of stereo controllers and screen used.

3D requirements

Stereo 3D applications require a stereo 3D-capable source, special hardware and software setups, and the projector's 3D Settings menu option to control the projector's processing, synchronization, and displaying of the stereoscopic 3D source material.

Hardware requirements

Note the following hardware requirements for stereo 3D applications:

- Christie Digital Systems Mirage 4K Series projector
- 3D stereo sync cable for Direct-Input 3D (and frame doubled)
- A source, usually a computer with a 3D graphics card(s)
- Emitter for controlling active shutter glasses

or

A qualified device that mounts in front of the lens of the projector to process the light from the lens into a passive polarized light. Contact your Immersive dealer for more information.

Software and content requirements

Note the following software and content requirements for stereo 3D applications:

- Any 3D computer software that supports 3D stereo on a supported computer(s) with associated graphic cards (suggested cards include ATI or NVIDIA)
- A video stream from a video source prepared to be sequential content (for Direct-Input 3D) or two video streams from a video source that has been prepared to be supplied left eye and right eye concurrently and frame locked (Dual-Input 3D)

Active stereo 3D configuration

The following diagram shows the typical hardware configuration for active stereo 3D systems:

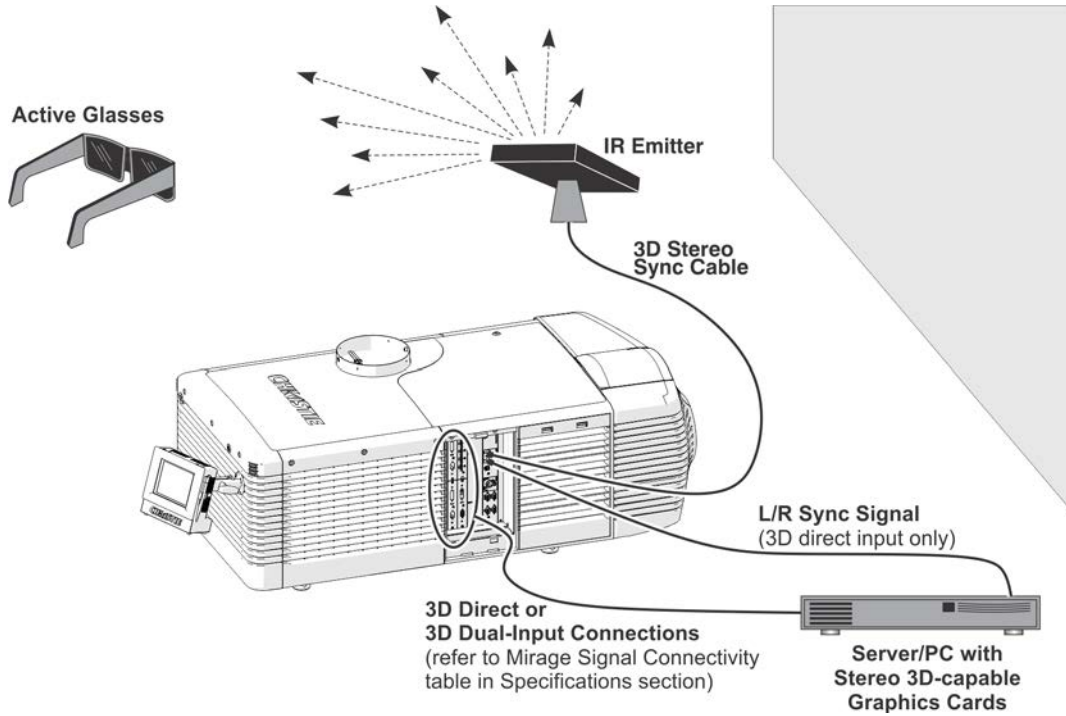

In response to the 3D Sync Out signal from the projector, the IR emitter emits an infrared signal to a receiver in the active 3D shutter glasses. This synchronizes the active glasses to alternatively open and close for the active stereo 3D applications.

Passive stereo 3D configuration

The following diagram shows the typical hardware configuration for passive stereo 3D systems:

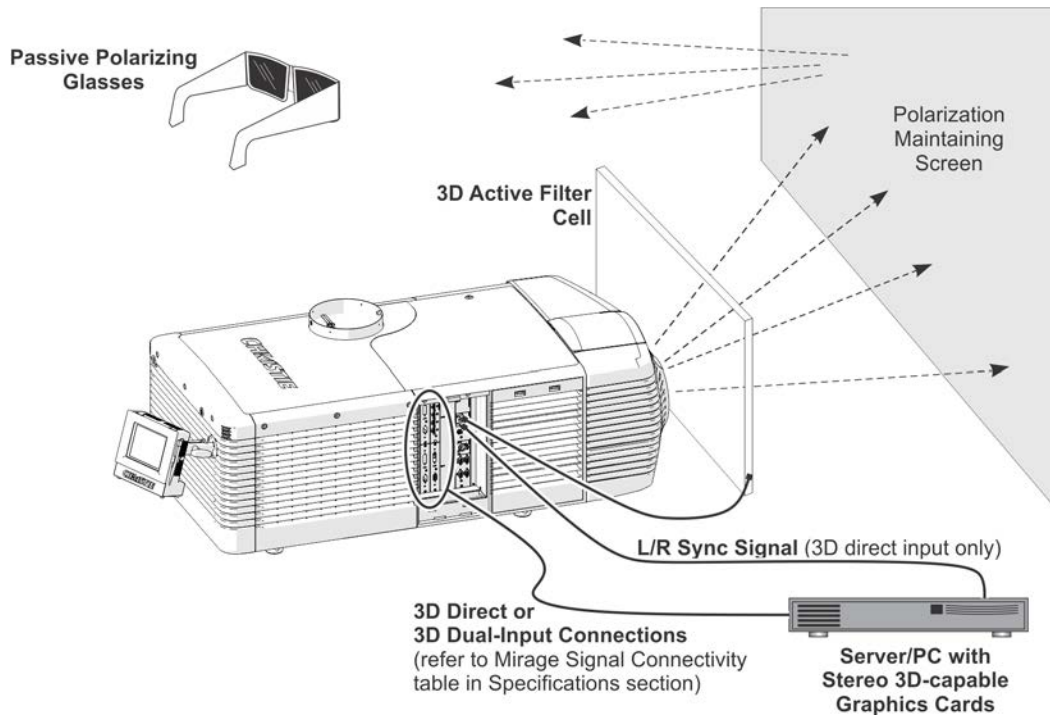

For operation with passive glasses, a 3D polarization filter is placed in front of the lens and is synchronized to the projected frames with the 3D Sync Out signal.

3D system timing

Consult the documentation for your glasses or polarization filter and keep their specifications in mind when configuring the projector for 3D operation. The projected video must be optimized for the glasses' shutter speed or polarization filter performance to prevent obvious "ghosting" of the video content (known as cross-talk in stereo 3D applications) or other more subtle color artifacts. Visual performance can be optimized by adjusting the Dark Interval and the 3D Sync Delay settings.

3D input video configurations

The stereo 3D input video stream may be supplied from the video server to the projector in two configurations: Direct-Input 3D or Dual-Input 3D.

Configuration	Description
Direct-Input 3D	<p>In this configuration a single video stream is provided by the video server, with the left eye and right eye frames supplied as alternate frames within the video stream. A 3D Input Sync may be used to identify the left eye frames.</p> <p>The Direct-Input 3D video stream may be supplied by either a Four-Port input video configuration (such as four cables each supplying one quadrant of the image) or an One-Port input video configuration (such as one cable supplying the entire frame).</p>
Dual-Input 3D	<p>In this configuration two video streams are provided by the video server, with the left eye supplied by one stream and the right eye supplied by the other. The video streams are frame locked and supplied concurrently.</p> <p>The Dual-Input 3D video streams may be supplied by either two Four-Port input video configurations (such as four cables each supplying one quadrant of the image for each eye, with a total of eight cables) or two One-Port input video configurations (such as one cable supplying the entire frame for each eye, with a total of two cables).</p>

Set up a single Mirage 4K to display 3D content

The projector must be installed correctly to display 2D content (lamp installed, optically aligned, focused, and so on) before completing the following steps to display the 3D content:

1. Confirm the emitter setup.
2. Configure the projector for the 3D source.

Confirm the emitter setup

1. To set the 3D output to emitter, tap **Main > 3D Settings > 3D Sync Output** and select **To Emitter**.
2. To enable the 3D test pattern, tap **Main > 3D Settings** and select **3D Test Pattern**.
3. To configure the dark interval so the amount of dark time aligns with the amount of time required for the glasses to switch, tap **Main > 3D Settings > Dark Interval** and adjust the dark interval as required.
4. View the displayed test pattern. If you can see both Ls and Rs with both eyes, increase the dark interval until Ls are only visible to the left eye and Rs are only visible to the right eye.
5. Optionally, adjust the 3D Sync delay as necessary.

This adjusts the timing of the sync pulse in relation to the dark time transition on the DMDs. Use the default value of 0 as a starting point.

Configure the projector for the 3D source

1. Select the channel (from the Home tab) best suited for the 3D source.
2. To select the correct EDID timing, tap **Main > Configuration > EDID Timing Select** and select the required EDID timing.
3. Connect all the required cables between the 3D source and the projector.
4. Configure your 3D source.

Connect Devices

This section provides information and procedures for connecting external devices to the projector. Communication and input ports are located on the projector side input panel, accessed by removing the input panel cover. When connecting devices, you can route cables through the opening in the frame to the side input panel or directly to the video option cards and MCPU. The image below shows the video option card slot numbers and the MCPU panel.

Input signal devices are connected to the video option cards and the option card slot numbers are important for some types of input signals. Communication devices are connected at the MCPU panel.

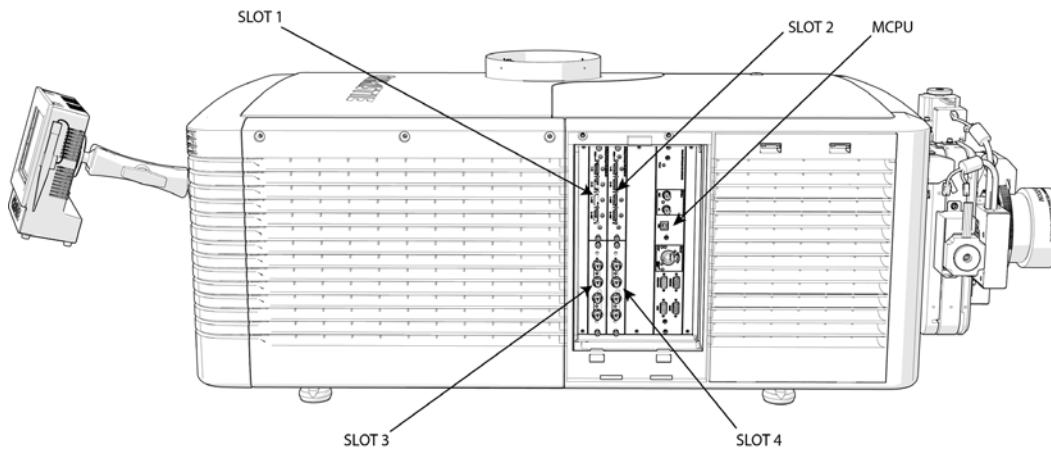

Input video mapping

Video input mapping depends on the type of cards used for the Four-Port or Two-port input configurations.

Four-Port: 3GIC, TDPIC, THIC cards

The following table shows the video quadrant mappings for the 3GIC, TDPIC, and THIC Four-Port input configurations:

Four-Port Input Configuration—Two Cards (1)		Quadrants	Columns
Slot 1	1-In	Top left	1 (left most)
Slot 1	2-In	Bottom left	2

Slot 2	1-In	Top right	3
Slot 2	2-In	Bottom right	4
Four-Port Input Configuration—Two Cards (2)		Quadrants	Columns
Slot 3	1-In	Top left	1 (left most)
Slot 3	2-In	Bottom left	2
Slot 4	1-In	Top right	3
Slot 4	2-In	Bottom right	4
Four-Port Input Configuration—Four Cards		Quadrants	Columns
Slot 1	1-In	Top left	1 (left most)
Slot 2	1-In	Top right	2
Slot 3	1-In	Bottom left	3
Slot 4	1-In	Bottom right	4

Four-Port: DDIC card

The following table shows the video quadrant mappings for the DDIC Four-Port input configuration:

Four-Port Input Configuration		Quadrants	Columns
Slot 1	1-Dual Link DVI-I	Top left	1 (left most)
Slot 2	1-Dual Link DVI-I	Top right	2
Slot 3	1-Dual Link DVI-I	Bottom left	3
Slot 4	1-Dual Link DVI-I	Bottom right	4

Two-Port: TDPIC card

Two-Port Input Configuration—Two Cards (1)		Columns
Slot 1	1-In	1 (left most)
Slot 2	1-In	2
Two-Port Input Configuration—Two Cards (2)		Columns
Slot 3	1-In	1 (left most)
Slot 4	1-In	2

Two-Port: DDIC card

Two-Port Input Configuration—Two Cards (1)		Columns
Slot 1	1-Dual Link DVI-I	1 (left most)
Slot 2	1-Dual Link DVI-I	2
Two-Port Input Configuration—Two Cards (2)		Columns
Slot 3	1-Dual Link DVI-I	1 (left most)

Slot 4	1-Dual Link DVI-I	2
--------	-------------------	---

Connect a video source using DisplayPort

The Twin DisplayPort Input card (TDPIC) accepts digital video data from the DisplayPort sources. The input configurations listed below are supported.

Input Configuration	Description	Requirements
Four-Port	Enables connection of four DisplayPort cables to two or four TDPIC cards. Each DisplayPort input supplies one quadrant or column of a 4K input image. This configuration supports high resolution and high frame rate input video streams.	Two or four TDPIC cards
Four-Port, Dual-Input 3D	May be used for Dual-Input 3D configurations.	Four TDPIC cards
Two Port	Enables connection of two DisplayPort cables to two TDPIC cards. Each DisplayPort input supplies one of two columns of a 4K input image.	Two TDPIC cards
Two-Port Dual Input 3D	May be used for Dual-Input 3D configurations.	Four TDPIC cards
One-Port	Enables connection of one DisplayPort cable to the 1-IN input of a TDPIC card (any slot). In this configuration the DisplayPort input supplies the entire video raster.	One TDPIC card
One-Port, Dual-Input 3D	May be used for Dual-Input 3D configurations.	One TDPIC card

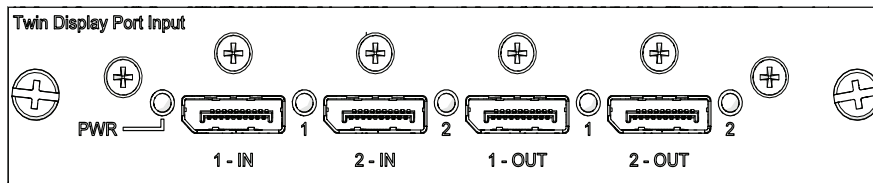

For information on the video quadrant mapping for Four-Port and Two-Port configurations, see [Two-Port: TDPIC card](#) on page 38 and For limitations of one card use for One-Port Dual-Input 3D, see [Mirage signal connectivity](#) on page 84.

Connect a video source using 3G Input card

The 3G Input card (3GIC) accepts digital video data from HD and 3G-SDI (Serial Digital Interface) sources. The input configurations listed below are supported.

Input Configuration	Description	Requirements
Four-Port	Enables connection of four SDI cables to two 3GIC cards. Each SDI input supplies one quadrant or column of a 4K input image. This configuration supports high resolution and high frame rate input video streams.	Two 3GIC cards
Four-Port, Dual-Input 3D	May be used for Dual-Input 3D configurations.	Four 3GIC cards
One-Port	Enables connection of one SDI cable to the 1-IN input of a 3GIC card (in any slot). In this configuration the SDI input supplies the entire video raster.	One 3GIC card
One-Port, Dual-Input 3D	May be used for Dual-Input 3D configurations.	One 3GIC card

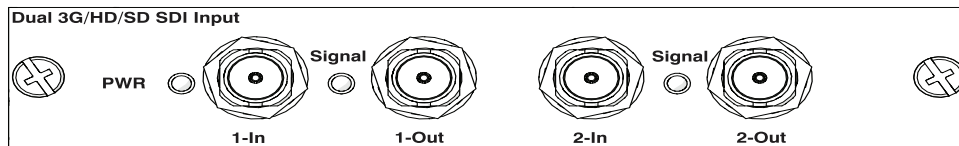

For information on the video quadrant mapping for Four-Port and Two-Port configurations, see [Two-Port: TDPIC card](#) on page 38 and For limitations of one card use for One-Port Dual-Input 3D, see [Mirage signal connectivity](#) on page 84.

Connect a video source using HDMI

The Twin HDMI Input card (THIC) accepts digital video data from HDMI sources. The input configurations listed below are supported.

Input Configuration	Description	Requirements
Four-Port	Enables connection of four HDMI cables to two THIC cards. Each HDMI input supplies one quadrant or column of a 4K input image. This configuration supports high resolution and high frame rate input video streams.	Two THIC cards
Four-Port, Dual-Input 3D	May be used for Dual-Input 3D configurations.	Four THIC cards
One-Port	Enables connection of one HDMI cable to the 1-IN input of a THIC card (in any slot). In this configuration, the HDMI input supplies the entire video raster.	One THIC card
One-Port, Dual-Input 3D	May be used for Dual-Input 3D configurations.	One THIC card

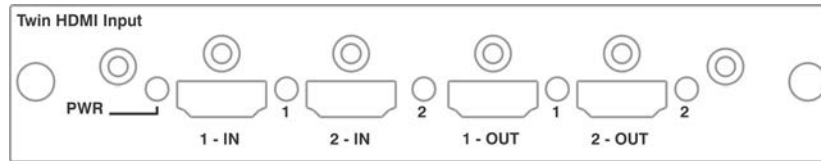

For information on the video quadrant mapping for Four-Port and Two-Port configurations, see [Two-Port: TDPIC card](#) on page 38 and For limitations of one card use for One-Port Dual-Input 3D, see [Mirage signal connectivity](#) on page 84.

Connect a video source using DVI

The Dual Link DVI Input card (DDIC) accepts digital video data from DVI sources. It does not support incoming analog signals. The input configurations listed below are supported.

Input Configuration	Description	Requirements
Four-Port	Enables connection of four DVI cables to four DDIC cards. Each DVI input supplies one quadrant or column of a 4K input image. This configuration supports high resolution and high frame rate input video streams.	Four DDIC cards
Two Port	Enables connection of two DVI cables to two DDIC cards. Each DVI input supplies one of two columns of a 4K image.	Two DDIC cards
Two-Port Dual-Input 3D	May be used for Dual-Input 3D configurations.	Four DDIC cards
One-Port	Enables connection of one DVI cable to the DVI input of a DDIC card (in any slot). In this configuration, the DVI input supplies the entire video raster.	One DDIC card
One-Port, Dual-Input 3D	May be used for Dual-Input 3D configurations.	Two DDIC cards

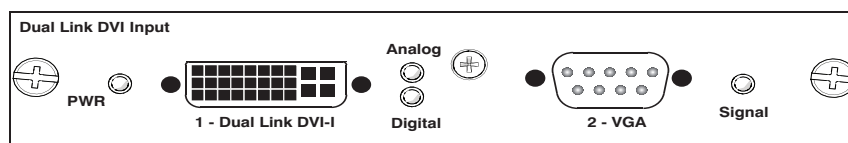

Only one Four-Port input configuration is available for DVI inputs. For information on the video quadrant or column mapping for the DDIC input configuration, see [Two-Port: TDPIC card](#) on page 38.

Select a video source

After connecting a video source to the projector, you must select it using the touch panel controller (TPC).

1. On the TPC, select **Input > Channel**.
2. Scroll the list of channels until you find the channel that best matches your configuration.
3. Tap the channel.

An image appears on the screen. If an image does not appear on the screen, repeat steps 1 to 3, selecting a different channel.

Connect devices to the 3D Sync ports

The 3D Sync Input and Output ports located on the MCPU faceplate provide a convenient method for interfacing the projector to the 3D stereo projection system. The 3D Sync Input should be connected to the video source for synchronization of the left eye/right eye frames of Direct input 3D or for frame doubled content. The 3D Sync Input is not required for Dual-Input 3D. The 3D Sync Output is available for control of an IR Emitter for active glasses or a polarization device for passive glasses.

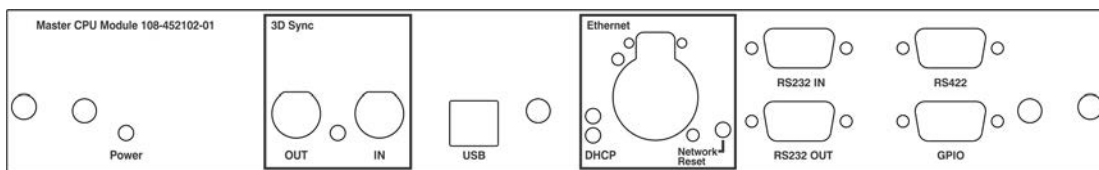

Connect a computer or server

To communicate with a remote computer, server or an existing network, use an RJ-45 cable to connect the Ethernet hub or switch to the Ethernet port, located on the projector MCPU faceplate. When using the Christie serial protocol over Ethernet, connect to port 3002.

For applications or equipment using serial communications, use the Christie-proprietary serial protocol to communicate with the RS422 port or the RS232 ports on the MCPU faceplate.



Notice. Failure to comply with the following may result in property damage.

The RS232 port located on the MCPU faceplate uses Christie-proprietary protocol and is intended for Christie accessories or automation controllers only. For more information on the serial commands, see the [Mirage 4K Serial API Commands Technical Reference \(P/N: 020-101449-XX\)](#).

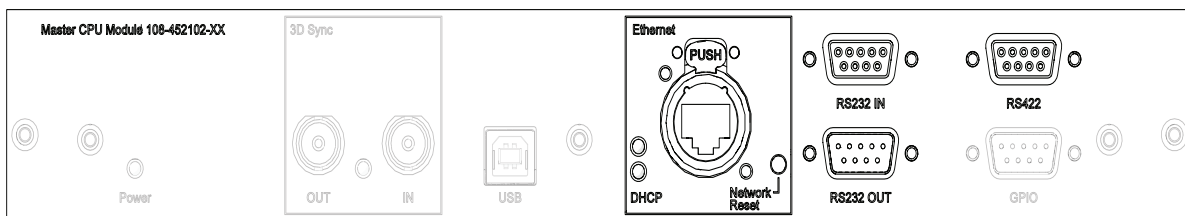

Set up the ethernet

Ethernet is setup to obtain an IP address automatically if a DHCP server is on the network. To modify IP settings, or manually enter an address.

1. On the touch panel controller, tap **Menu > Configuration > Ethernet Settings > Modify IP Settings**.
2. Set the network information for the projector:
 - To obtain information automatically from the network, tap **Automatic**.
 - To manually enter the network information, tap **Manual** and enter the **IP Address**, **Subnet Mask** and **Gateway** (optional).
3. Click **Ok**.

Adjust the Image

This section provides information and procedures for adjusting the projector image.

Select screen image orientation

The projector supports front projection, rear projection, front projection inverted, and rear projection inverted.

1. On the touch panel controller, tap **Menu > Configuration > Screen Image Orientation**.
2. Select the required orientation from the list.

Maximize light output

To ensure optimal operation, use LampLOC to adjust the lamp position whenever a new lamp is installed or changes in the projector orientation (for example, from/to portrait mode).

1. On the touch panel controller, tap **Menu > Lamp > LampLOC**.
2. Tap **Auto LampLOC**.

Align the image

This procedure ensures that the image reflected from the digital micromirror device (DMD) is parallel and centered with the lens and screen. Complete this procedure before adjusting boresight.

1. Verify that the projector is properly located and positioned relative to the screen.
2. Display a test pattern that can be used to analyze image focus and geometry.
3. Perform a preliminary focus and (if available) a zoom adjustment with the primary lens installed. Always focus the center of the image first.
4. With the test pattern on screen, re-check the projector leveling so the top edge of the image is parallel to the top edge of the screen.

For more details, see [Position the projector](#) on page 24 and [Work with lenses](#) on page 56.

Adjust offset

Project an image with the primary lens. Always adjust offset before adjusting boresight.

Select a framing test pattern and then adjust the vertical (A) and horizontal (B) offsets to display a square image on the screen, with minimal projector aiming error.

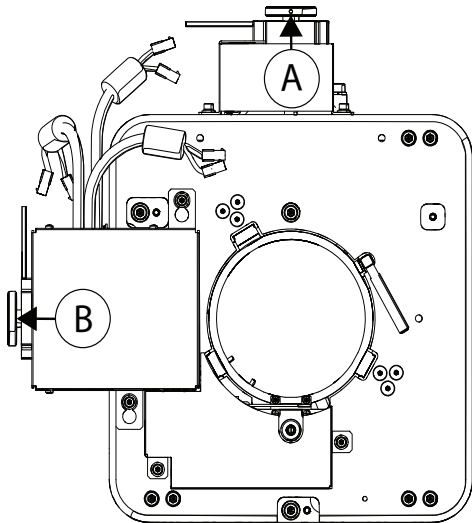

For the best optical performance and minimal keystone, use offsets instead of aiming at the center of the image, in off-axis installations.

Avoid extreme tilts or offsets. Corner vignettes on a white test pattern indicate extreme offset that should be avoided using mechanical alignment.

Adjust horizontal boresight



Warning! Failure to comply with the following could result in death or serious injury.

When doing optical adjustments on an operating projector and the top lid is removed, everyone within the immediate vicinity must wear safety glasses with side shields and Christie approved protective safety clothing (P/N: 598900-95).

The purpose of boresight adjustment is to balance the tilt of the lens mount to compensate for screen-to-projector tilt.

1. Loosen the lens mount stabilization screw (D).

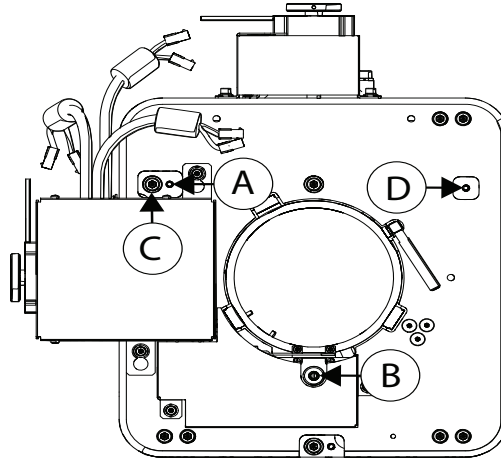

2. Loosen the horizontal lock screw (A).
3. Extend the lens focus (B) completely.
4. Adjust the **Focus** using the focus knob to retract the lens. Watch the image at the left edge of the screen until it comes into focus. If the entire screen is in focus, proceed to step 7.
5. Continue retracting the lens.
 - a. If the right side of the image comes into focus before the lens is completely retracted, adjust the horizontal boresight bolt (C) to balance the left and right edges.
6. If the right side of the image fails to focus, adjust the horizontal boresight bolt (C). When both sides appear equally blurry, adjust the offsets to re-center the image. Repeat steps 1 to 5 until both sides of the image are focused.
7. Tighten the lock screw (A) and the lens mount stabilization screw (D) to maintain the adjustments.
8. Check the boresight again.
9. Unless proceeding to adjust vertical boresight, perform a lens calibration.

For more details, see [Calibrate the lens motors](#) on page 75.

Adjust vertical boresight



Warning! Failure to comply with the following could result in death or serious injury.

When doing optical adjustments on an operating projector and the top lid is removed, everyone within the immediate vicinity must wear safety glasses with side shields and Christie approved protective safety clothing (P/N: 598900-95).

1. Focus the image at the top edge of the screen

2. Loosen the lens mount stabilization screw (D).

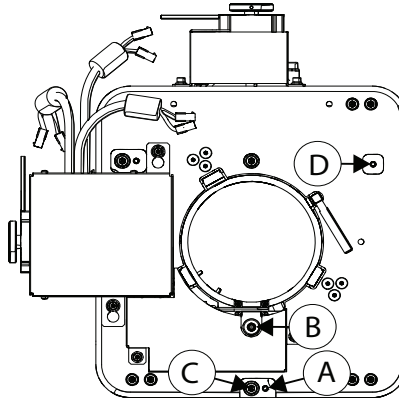

3. Loosen the vertical lock screw (A).
4. Extend the lens focus (B) completely.
5. Adjust the **Focus** knob to retract the lens. Watch the image at the top edge of the screen until it comes into focus. If the entire screen is in focus, proceed to step 8.
6. Continue retracting the lens.
 - a. If the bottom edge of the image comes into focus before the lens is completely retracted, adjust the vertical boresight bolt (C) to direct or aim the lens mount UP towards the top of the screen to balance out the top/bottom edges.
 - b. If the top edge of the image is not in focus, adjust the vertical boresight bolt (C) to direct or aim the lens mount toward the bottom of the screen.
7. When both sides appear equally blurry, adjust the horizontal and/or vertical offset to re-center the image on the screen.
8. Repeat Steps 2 to 5 until the top and bottom of the screen are both well-focused.
9. Re-focus the center of the image. The goal is for good focus at the center and on all sides.
10. Tighten the lock screw (A) and the lens mount stabilization screw (D) to maintain the adjustments.
11. Check the boresight again.
12. Perform a lens calibration.

For more details, see [Calibrate the lens motors](#) on page 75.

Lock the lens offsets

The lens locking feature reduces image vibration. For most applications lens locking is not necessary.



Warning! Failure to comply with the following could result in death or serious injury.

When doing optical adjustments on an operating projector and the top lid is removed, everyone within the immediate vicinity must wear safety glasses with side shields and Christie approved protective safety clothing (P/N: 598900-95).



Notice. Failure to comply with the following may result in property damage.

Lens locking requires the disabling of the lens offset and focus. Do not attempt to adjust the lens offset with the offset locking screws installed.

1. Use the touch panel controller (TPC) or manually adjust the lens offsets to the required position.
2. Unpack and install the three lens offset locking screws.

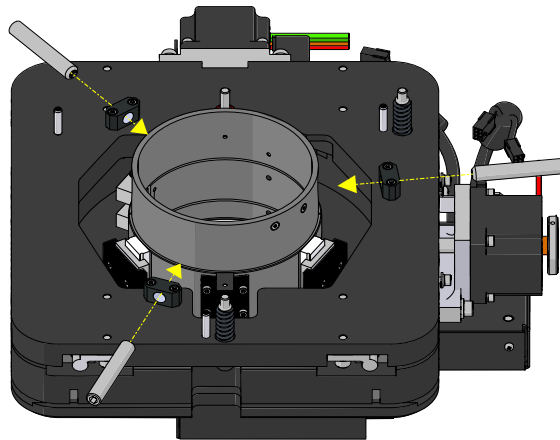

3. Tighten each locking screw until each screw contacts the lens offset collar.

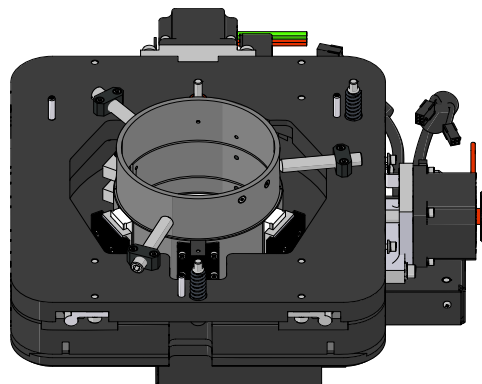

4. With equal pressure, tighten each locking screw against the lens offset collar.
5. Disconnect the lens motor communication cable.



When the lens motor communication cable is disconnected, the projector displays an error message on the TPC or the LCD display, identifying the loss of communication with the lens mount motors. Ignore this error message.

Adjust DMD convergence

A convergence problem occurs when one or more projected colors (red, green, blue) appears misaligned when examined with a convergence test pattern. Normally, the three colors should overlap precisely to form pure white lines throughout the image and one or more poorly converged individual colors may appear adjacent to some or all of the lines.

Contact your Christie accredited service technician to correct DMD convergence issues.

Color correction

The Mirage 4K25 provides predefined and custom color adjustments using the Color Correction menu. The available color adjustment controls are listed in the table below:

Menu	Description
Max Drives	Turns off all color adjustments allowing the projector to run at maximum brightness.
Color Temperature	Allows the specification of a color temperature as expressed in degrees Kelvin. Standard settings are: <ul style="list-style-type: none"> • 9300K—Close to the white of many computer monitors. • 6500K—Standard for color video in both standard and HD formats. • 5400K—Standard for graphics and black and white video. • 3200K—Useful if the projected image is to be filtered, or shot as part of a studio set illuminated with incandescent lighting.
HD Video	Sets the output color value to the HD video standard.
Custom	Allows custom color adjustments to be made by the projector operator.

Adjust color by temperature



Color temperature adjusts the overall color gamut and does not allow for precise adjustments of specific primary colors.

1. On the touch panel controller, tap **Menu > Configuration > Color Correction > Select Color Adjustment**.
2. From the list, select **Color Temperature**.
3. Tap **Color Temperature**.
4. Adjust the temperature value and tap **OK**.

Adjust color by precise chromaticity values



Adjusting the color chromaticity values overwrites any settings applied in the Color Saturation menu.

1. On the touch panel controller, tap **Menu > Configuration > Color Correction > Select Color Adjustment**.
2. From the list, select **Custom**.
3. Tap **Color Adjustments by X,Y**.
4. Adjust the precise hues of each primary color component.

Adjust color by saturation



Adjusting the color saturation overwrites any settings applied in the Color Adjustments by X,Y menu.

1. On the touch panel controller, tap **Menu > Configuration > Color Correction > Select Color Adjustment**.
2. From the list, select **Custom**.
3. Tap **Color Saturation**.
4. Adjust the hue of each primary color by using more or less of it in relation to the other primary colors.

Adjust the fold mirror



Warning! Failure to comply with the following could result in death or serious injury.

When doing optical adjustments on an operating projector and the top lid is removed, everyone within the immediate vicinity must wear safety glasses with side shields and Christie approved protective safety clothing (P/N: 598900-95).

If a corner or edge of an image is missing, the fold mirror might be misaligned with the optical system. To correct this issue:

1. Remove the four screws securing the fold mirror plate, on the underside of the projector.
2. Adjust the fold mirror:
 - Adjust the screw on the lens side to raise or lower the image.

- Adjust the screw on the lamp side to move the image left or right.

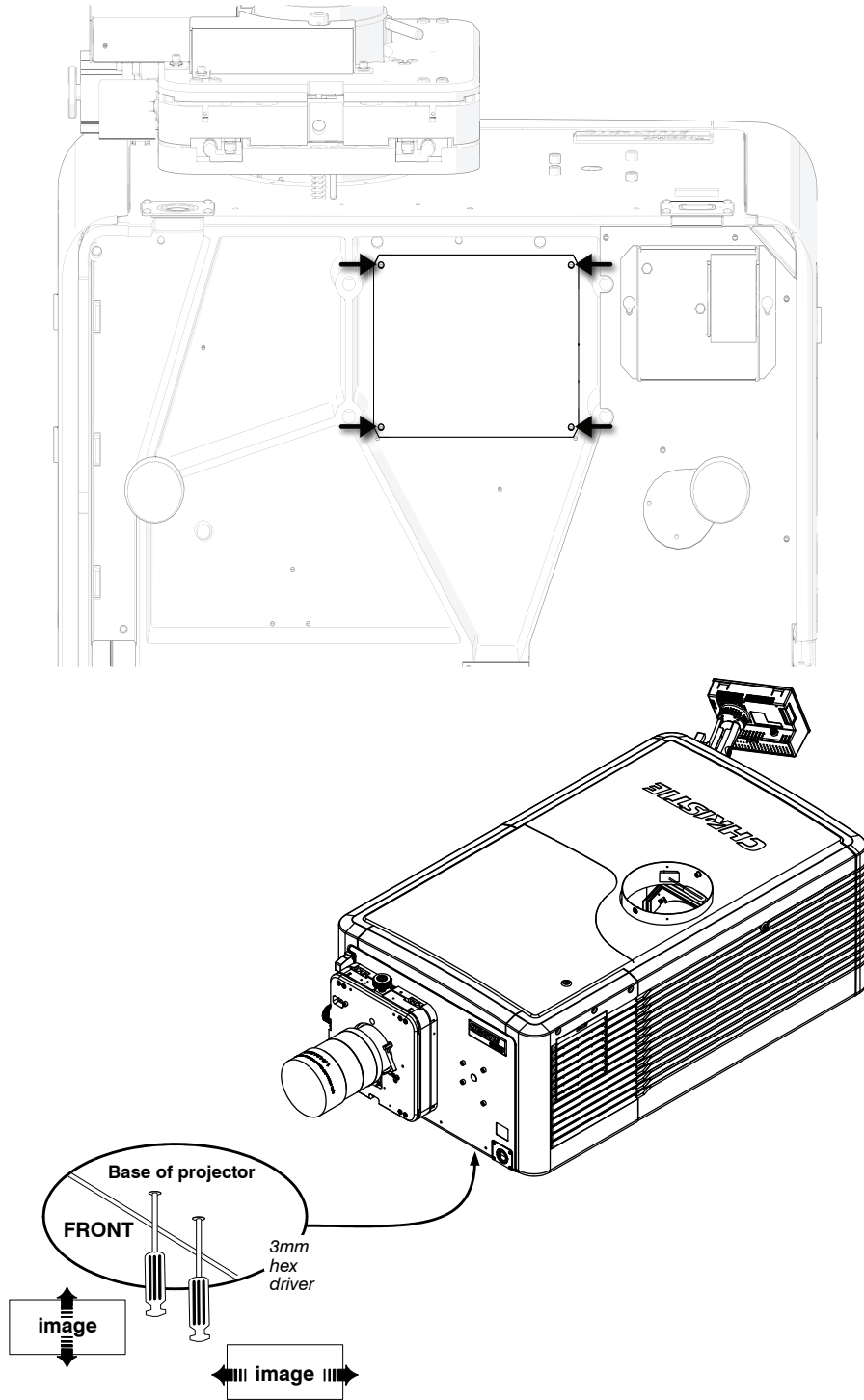

Operation

This section provides information and procedures for operating the projector.

Projector LED status indicators

LED	State	Description
Solid Green	On	Video electronics are on, the lamp is on.
Solid Yellow	Standby mode	Video electronics are off, lamp is off.
Solid Green, Yellow and Red	AC is on	MCPU board software has not started initialization.
Flashing Green	Warm up	Video electronics are initializing, lamp is striking and warming up.
Flashing Yellow	Cool down	Lamp is off, video electronics and lamp are cooling down.
Flashing Red	Alarm or warning preset	Problem with the projector must be addressed.
Flashing Green and Yellow	AC on to standby	MCPU board software has started initialization.

Turn the projector on



Warning! Failure to comply with the following could result in death or serious injury.

- Do not attempt to turn the projector on if the AC supply is not within the specified voltage range.

1. Set the breaker switch on the projector baseplate to the on position.
2. When the projector reaches standby, on the touch panel controller, tap **Home** > **Power**.

For more details on the specified voltage range, see [Power requirements](#) on page 90.

LED expected behavior on power up

The following table shows the expected behavior of the projector LED and the MCPU board power LED on power up:

Action/Event	Projector LEDs	MCPU Board Power LED
Applying AC power to the projector head	Solid red Solid green Solid yellow	Yellow
Within the first second	Solid red Solid green Solid yellow	Blinking green
At approximately 30 seconds	Off red Blinking yellow Blinking green	Blinking green
At approximately 50 seconds	Off/blinking red Solid yellow Off green	Solid green

At approximately one minute and 15 seconds, the TPC indicates that it is connected and shows the home page.

Turn the projector off

1. On the touch panel controller, tap the **Home** tab.
2. Tap **Power**.



When powering off in preparation for inspection or maintenance, always disconnect from AC and set the projector breaker to the off positions.

Work with lamps

This section provides information and procedures for optimizing lamp performance to ensure the brightest, most uniform image possible for the life of the lamp.

Adjust lamp power

1. On the touch panel controller, tap **Menu > Lamp > Lamp Power**.
2. Use the slider or enter a value to adjust the lamp power.
3. Tap **OK**.

Adjust the lamp position with LampLOC

Use LampLOC to configure the lamp position and geometry when installing a new lamp in the projector or at any other time when the lamp performance needs to be optimized. Before adjusting LampLOC, make sure the following criteria is met:

1. Make sure the lamp is on and the douser (shutter) is open during adjustment.
Christie recommends a 10-minute warm-up.
2. Perform the LampLOC procedure.

For more details, see [Calibrate the lamp](#) below.

Calibrate the lamp

The lamp should be re-calibrated when any of the following conditions are met:

- After the lamp has been replaced.
 - After the projector has been moved and/or jostled.
 - After the lamp motor IMCB has been replaced.
1. On the touch panel controller, tap **Menu > Lamp > LampLOC**.
 2. Tap **Auto LampLOC**.
 3. Adjust optical components if required.

Manually adjust the lamp position

1. On the touch panel controller, tap the **Home** tab.
2. Tap **Test Pattern** and select **17pt White Field Test Point**.
3. Mount a light meter on a tripod and center it with the lens.
The distance from the lens does not matter. An attenuator or an internal foil aperture may be required.
4. Tap **Menu > Lamp > LampLOC**.
5. Tap the directional arrows to adjust the value displayed in the **Z** field, until the brightness reading in front of the lens is maximized.
6. Tap the directional arrows to adjust the values displayed in the **X** and **Y** fields until the brightness values in each field are maximized.
7. For a finer adjustment, repeat steps 5 and 6 but take the readings at the center of the screen instead of at the lens.

View lamp information

To view a history of all previously installed lamps, on the touch panel controller, tap **Menu > Lamp > Lamp History**.

Track lamp intensity with LiteLoc

Use the LiteLoc feature to maintain a constant level of brightness over the lifetime of the lamp.

1. On the touch panel controller, tap **Menu > Lamp > Lamp Power**.
2. To adjust the lamp power, use the slider or enter a value until the display is as bright as required.
3. Tap **OK**.
4. Tap **Lamp Mode**.
5. Tap **Constant Intensity**.

Notice the Lamp Power option is greyed out so you cannot adjust it. To readjust the lamp power, select **Lamp Mode > Lamp Power**. From the Lamp Power option, adjust the power setting as applicable.

Lamp details

Lamp Type	Replace Before	Min. Lamp Power	Max. Lamp Power
CDXL-20 (2.0 kW)	2400 hours	1000W (50%)	2200W (110%)
CDXL-20SP (2.0 kW)	3200 hours	1400W	2000W
CDXL-30 (3.0 kW)	1500 hours	2000W (67%)	3300W (110%)
CDXL-30SD (3.0 kW)	1500 hours	2100W	3000W
CDXL-30SP (3.0 kW)	1900 hours	2100W	3000W

Record new lamp information



The lamp serial number is an alphanumeric, user-defined field. Christie recommends choosing a distinct and descriptive name for every individual lamp.

1. On the touch panel controller, tap **Menu > Lamp > Change Lamp**.
2. Enter a **Lamp Type**, **Serial Number** and **Hours Used**.
3. Tap **Apply Lamp Change**.
4. Tap **Continue**.

Add lamp end-of-life indicator

Specify the number of hours remaining before issuing an end-of-life indicator for the lamp.

1. On the touch panel controller, tap **Menu > Lamp > Lamp life warning at (hours)**.
2. To specify the number of hours remaining before issuing an end-of-life indicator, enter a value or use the plus and minus buttons to increase or decrease the value.

A value of zero disables the feature.

3. Tap **OK**.

When the specified number of hours is reached, a Lamp Hours - past expiry warning is issued.

Work with lenses

The lens mount secures the projection lens to the projector and provides setup adjustments to correct boresight, and control focus, zoom, and offsets.

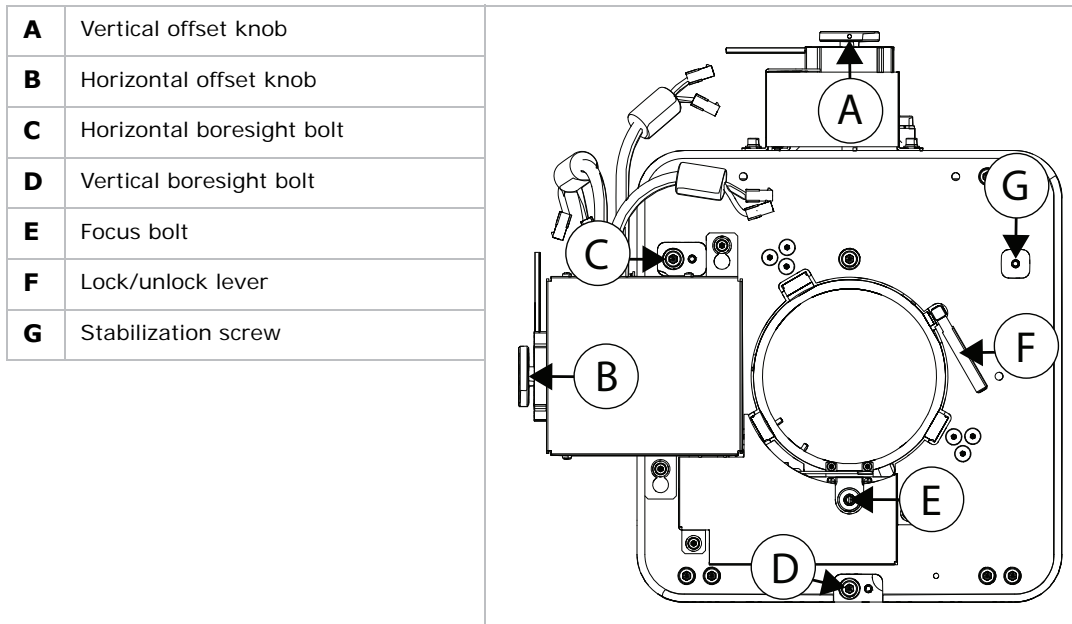

4. To electronically control the focus, zoom, and offsets, on the touch panel controller, tap the **Lens** tab.



Calibrate the lens motors when any of the following conditions are met:

- After a lens change.
- After the projector is moved and/or jostled.
- After the lens motor IMCB has been replaced.

Select a channel

The projector uses pre-configured channels to determine how to display images from different sources. Each channel file contains the optimum processing and display settings for the source. Channels can be selected through the **Home** tab on the touch pad controller (TPC).

Enable warping and blending

Use edge blending to combine several projected images into one single, seamless image. Use warping to project images on any surface shape.

1. Create the warp and blend files using the Twist application
For details, see the *Twist 2.0 User Manual (P/N: 020-101380-xx)*.
2. Upload the warp and blend files to the projector.
For details, see the *Twist 2.0 User Manual (P/N: 020-101380-xx)*.
3. On the touch panel controller, tap **Main > Configuration > Geometry**.
4. To select a warp setting, tap **Geometry Correction** and tap the required warp.
5. To select a blend setting, tap **Edge Blending** and tap the required blend.
6. To select a black level blend setting, tap **Black Level Blending** and tap the required black level blend.
7. To turn off warping, blending, or black level blending, tap **Off**.

Send error notifications to specified devices

If an error occurs on the projector, notifications can be sent to three different devices.

1. On the touch panel controller, tap **Menu > Communications > SNMP**.
2. Tap **Trap IP Address 1**.
3. For the device you want to send error notifications to, enter the IP address.
4. Tap **OK**.
5. To add a second or third device, repeat steps 2 to 4.
6. Select the options you want to monitor.
Options include lamp fault, lamp life, power, fan stall, and thermal sensors.

Menus

This section provides information and procedures for using projector menus. Use the projector menus to adjust projector settings and view status information.

Touch panel controller

The touch panel controller (TPC) is a touch-sensitive screen. Use the TPC to control the projector, manage sources, adjust the display, and view status information. The TPC is mounted on the rear of the projector and can be adjusted to improve the TPC viewing angle. A side USB port can be used to download log files and install software upgrades.

For remote applications, the TPC can be dismantled from the projector and used with the optional cable to allow projector control from a maximum distance of 100 ft (30 m).

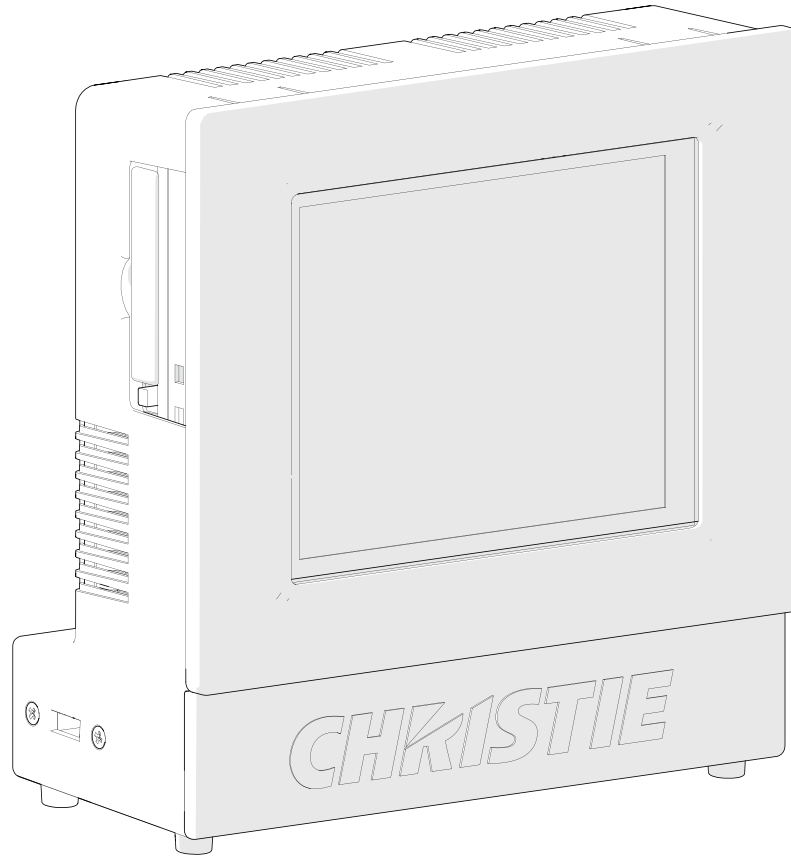

Tab structure

The touch panel controller (TPC) windows are structured across a series of six tabs on the top of the display:

Tab	Description
Home	Quickly add and select channels, display test patterns, activate the shutter and control the projector power.
Menu	Access the projector controls and settings. Available submenus: <ul style="list-style-type: none"> • Image Settings • Lamp • Configuration • Communications • General
Lens	Adjust the lens offset, focus, and zoom motors. These controls can be adjusted by either tapping the required directional arrow, or by entering a numerical value.

Tab	Description
Status	Display the status of projector control states and settings. The status windows are for reporting purposes and all fields are read-only. For details, see Status tab details on page 61.
Admin	Display log files, access the interrogator, create files, perform restores, and perform upgrade procedures. Available submenus: <ul style="list-style-type: none">• Upgrade—See Upgrade the projector software on page 63.• Interrogator—See Run the projector interrogator on page 81.• TPC Logs—See Save TPC log files on page 81.• Backup—See Back up projector settings on page 63.• Restore—See Restore settings from a local backup profile on page 64.
About	Display legal information regarding software licensing and usage agreements.

Menu tab details

Menu	Description
Image Settings	Adjust image settings such as color space, sharpness, gamma function, ambient light, and frame delay.
Lamp	Adjust the lamp power, calibrate the lamp, view lamp history and to input new lamp information when performing a lamp change. Available options: <ul style="list-style-type: none"> • Lamp Mode—See Track lamp intensity with LiteLoc on page 55. • Lamp Power—See Adjust lamp power on page 53. • Lamp life warning at (hours)—See Add lamp end-of-life indicator on page 55. • LampLOC—See Adjust the lamp position with LampLOC on page 54. • Lamp History—Display the history of all previously installed lamps. (Read-only) • Change Lamp—See Record new lamp information on page 55.
Configuration	Adjust the projected image orientation, colors, and the projector Ethernet settings. Available options: <ul style="list-style-type: none"> • Color Correction—See Color correction on page 49. • Image Orientation—See Select screen image orientation on page 44. • EDID Window Mode—Inform the source device to split the 4K video raster into two or four columns instead of four quadrants. • EDID Timing—See Configure the projector for the 3D source on page 36. • Diagnostics—Configure diagnostics such as freezing an image and selecting test patterns.
Communications	Adjust projector Ethernet settings and set notifications for projector errors. Available options: <ul style="list-style-type: none"> • Device name—Set the name of the projector. • Group name—Set the name of the group the projector belongs to. • Ethernet Settings—See Set up the ethernet on page 43. • SNMP—See Send error notifications to specified devices on page 57.
General	Adjust settings such as standby mode, auto power up, and video loop out. Provides current date and time information

Status tab details

Window	Description
Alarms	Display the location and the fault condition for any active alarms.
Configuration	Display the projector model, serial number, output resolution and date of manufacture.
Cooling	Display the status of the liquid cooling module and the cooling fans.
Lamp Info	Display the current lamp information, such as: lamp state, hours, type, serial number and power usage.
Serials	Display the serial numbers for all electrical components, such as: main control board, backplane, image processor, formatter boards and option cards.
Signal	Display the status of the four available option card slots.
System	Display system hardware control settings, such as: projector hours, pitch/roll, lamp motor status, lens motor status, and built-in self test.

Window	Description
Temperatures	Display the operating temperatures as reported by the internal thermal sensors.
Versions	Display the hardware and software versions for all electrical components, such as: main control board, backplane, image processor, formatter boards and option cards.

Backup, Restore, and Upgrade Projector Files

This section provides information and procedures for backing up, restoring, and upgrading projector files.

Upgrade the projector software

1. On the touch panel controller, tap **Admin > Upgrade**.
2. Tap **Upgrade**.
3. To select the upgrade file, tap **Browse**.
4. In the Select Package dialog, navigate to the location where the upgrade file is stored.
5. Tap the upgrade file and tap **Open**.
6. To automatically restart the projector when the upgrade is complete, tap **Restart when update complete**.
7. Tap **Install**.

Back up projector settings

1. On the touch panel controller, tap **Admin > Backup**.
2. To back up the settings, tap a backup file.
3. If required, enter or change the name.
4. Tap **OK**.

A message indicates the backup was successful.

Export backup settings to an external device

1. If exporting settings from the touch panel controller (TPC), insert a USB flash drive (properly formatted as FAT or NTFS) into the USB port on the side of the TPC.

or

If exporting settings from the PC application, skip to step 2.

If using the TPC, you cannot save to the TPC's on-board CF flash memory. You must export the settings to a USB flash drive. If using the PC application, you can export the files to location on the hard drive, a USB flash drive, and so on.

2. On the TPC, tap **Admin** > **Backup**.
3. Tap **Export**.
4. To save the file, in the Choose backup file location dialog, navigate to the location where you want export the file.
5. Tap **Save**.

Restore settings from a local backup profile

1. On the touch panel controller, tap **Admin** > **Restore**.
2. From the backup file list, tap the required file name.
3. Tap **Restore**.
4. At the prompt, tap **OK**.

Restore default settings

You need Service permissions to complete this procedure.

1. On the touch panel controller, tap **Admin** > **Restore**.
2. Tap **Defaults**.
3. Tap **Restore**.

Import file from an external device to restore settings

1. If importing settings using the touch panel controller (TPC), insert the USB flash drive containing the file into the USB port on the side of the TPC.

or

If importing settings using the PC application, skip to step 2.

If using the TPC, you must import the settings from a USB flash drive. If using the PC application, you can import the files from a location on the hard drive, a USB flash drive, and so on.

2. On the TPC, tap **Admin > Restore**.
3. Tap **Import**.
4. From the Choose file to restore dialog, navigate to the location where the file is stored.
5. Tap the file to select it.
6. Tap **Open**.

Maintenance

This section provides information and procedures for performing projector maintenance. Read through this section in its entirety before performing maintenance activities. When performing projector maintenance, obey all warnings and precautions.



Never attempt to access the lamp compartment while the lamp is on. Wait at least 10 minutes after the lamp turns off before powering down, disconnecting from AC and opening the lamp door.

The arc lamp operates at a high pressure that increases with temperature. Failure to allow the lamp to sufficiently cool before handling, increases the potential for an explosion causing personal injury or property damage.

Always wear manufacturer approved protective safety clothing (gloves, jacket, face shield) whenever the lamp door is open or when handling the lamp.



When accessing the restricted access location for projector service or maintenance, avoid exposure to the projector beam path by making sure to either:

- Power off the projector and disconnect from AC.
- Shutter the lamp to avoid emissions from the front aperture.



Danger! Failure to comply with the following results in death or serious injury.

ELECTRICAL SHOCK HAZARD! Always turn off, disconnect, and disengage all power sources to the projector before servicing.



Failure to comply with the following could result in death or serious injury.

- Qualified technician required for all installations.
- Never operate the projector without all of it's covers in place.



Caution! Failure to comply with the following could result in minor or moderate injury.

Only Christie accredited service technicians are permitted to open any enclosure on the projector and only if the AC power has been fully disconnected.

Maintenance shutdown

This process is **mandatory**. Always perform these steps before beginning any inspection or maintenance procedures on the projector.

1. If the projector is operating, turn it off and allow it to cool for a minimum of 10 minutes.
2. Set the projector breaker switch to the off position.
3. Set the lamp power supply's three breaker switches to the off positions.
4. Disconnect the projector from AC power.

Ventilation and cooling

Vents and louvers provide ventilation, both for intake and exhaust. Do not install the projector near a radiator, heat register, or within an enclosure. To ensure adequate airflow, keep a minimum clearance of 50 cm (20 inches) around the projector and never block or cover the vents.

Inspect and clean the airflow interlocks



Warning! Failure to comply with the following could result in death or serious injury. Never operate the projector with the fan switch removed or disabled.

The projector uses two airflow interlocks. Check and clean these switches to remove accumulated dust or dirt that could impede movement.

- Lamp blower vane switch, located within the lamp cooling compartment.
- Extractor vane switch, located inside the top duct on the projector lid.

Inspect and clean the exhaust duct

Inspect the exhaust duct regularly and confirm that:

- There are no obstructions or kinks within the ducting.
- All air intake areas are unobstructed.
- If using 2.0 or 3.0kW lamp, exhaust airflow must be at least 450 CFM (measured at the rigid end of the duct when not connected to the projector).



600 CFM is required when ambient temperatures exceed 25°C or elevation (above sea level) exceeds 3000 feet.

- If using 4.5 or 6.0kW lamp, exhaust airflow must be at least 600 CFM (measured at the rigid end of the duct when not connected to the projector).

Inspect and clean the lamp blower



Notice. Failure to comply with the following may result in property damage. Do **not** touch or bend the impeller blades or loosen the balancing weights.

A clogged blower impeller or motor can reduce air flow and lead to overheating and lamp failure.

1. Shut down the projector.
2. Remove the three screws securing the rear side cover.
3. Vacuum loose dirt from the lamp blower impeller.
4. If necessary, use a soft brush dampened with hot water.

or

Fold a clean microfiber cloth and dampen with methanol and wipe evenly with the smooth portion of the cloth that has no folds or creases. Do not apply finger pressure. Use the solution in the cloth to collect the dirt.

For more details, see [Maintenance shutdown](#) on page 66.

Inspect and fill the coolant reservoir



Warning! Failure to comply with the following could result in death or serious injury.

HAZARDOUS SUBSTANCE! The coolant used in the projector contains propylene glycol. Use caution when handling. Do not ingest.



Notice. Failure to comply with the following may result in property damage.

The coolant color may fade over time, however this does not impact the ability of the coolant to exchange heat. Only use coolant recommended by Christie in this projector.

The liquid cooling module (LCM) circulates coolant through the digital micromirror device (DMD) heat sinks. The coolant level should be checked every six months and should remain above the minimum level indicator and free from particulate and/or foginess.

Always use Christie approved **Coolant Propylene Glycol (P/N: 003-103148-XX)**. Always remove and refill the coolant reservoir outside of the projector and never overfill the reservoir beyond the top of the window. Use caution not to spill or let any of the coolant drip on or near the electronics.

Remove the liquid cooling reservoir

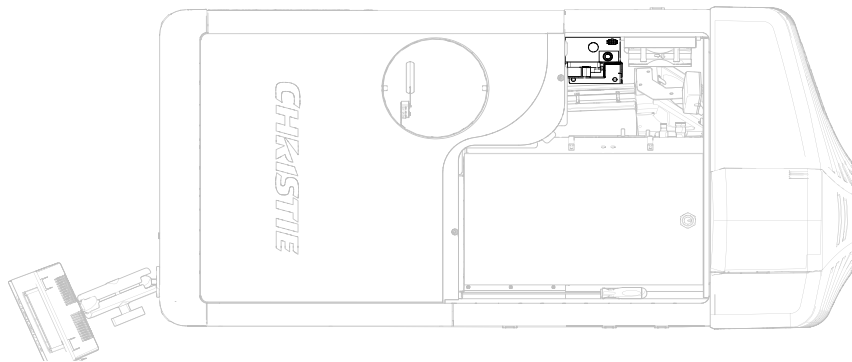

1. Shut down the projector.
2. Remove the front top cover.
3. Remove the radiator air filter.
4. Disconnect the blower on the LCM pump.

5. Disconnect the communications harness from the coolant reservoir.

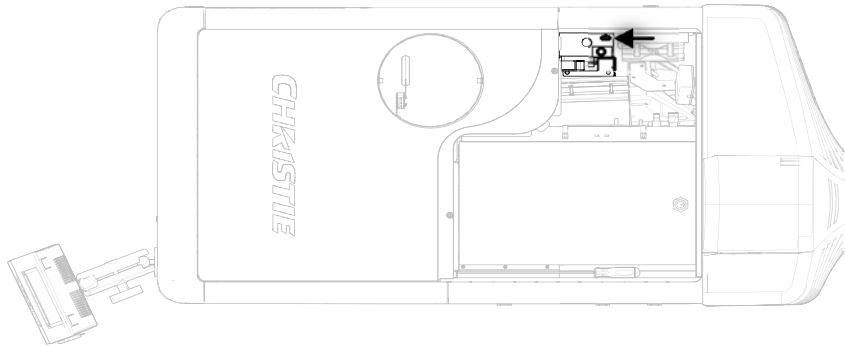

6. Disconnect the coolant hoses from the coolant reservoir.
7. Remove the three screws securing the reservoir bracket to the projector base plate.

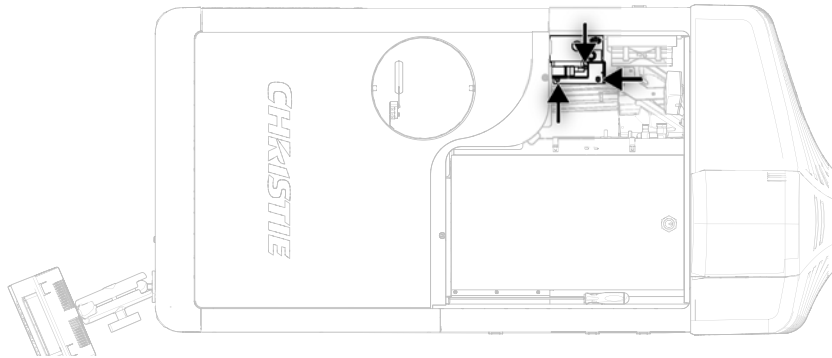

8. Lift and remove the reservoir from the projector.

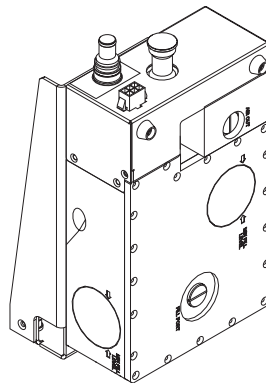

9. Refill the reservoir as needed.
10. Replace the cap.
11. To reinstall the liquid cooling reservoir, repeat these steps in reverse order.
12. Check for leaks, especially for any hoses that were removed around the filler cap.
13. Check for proper flow from the liquid cooling module.

For more details, see [Maintenance shutdown](#) on page 66.

Filtration



Notice. Failure to comply with the following may result in property damage.

Use only high efficiency Christie approved filters: light engine filter (five-pack)—P/N: 003-001184-XX, liquid cooling radiator filter—P/N: 003-003082-XX, and LAD filter (three-pack)—P/B: 03-001982-51P.

Never operate the projector without the filter installed. The air filters in this product cannot be cleaned thoroughly enough for reuse and can lead to the contamination of optical components.

Replace the light engine air filter

This filter is located on the lens side of the projector behind the air filter cover. Check the condition of this filter monthly. Replace the light engine air filter when replacing the lamp, or sooner when operating the projector in a dusty or dirty environment.

1. Release the two tabs on the air filter cover.

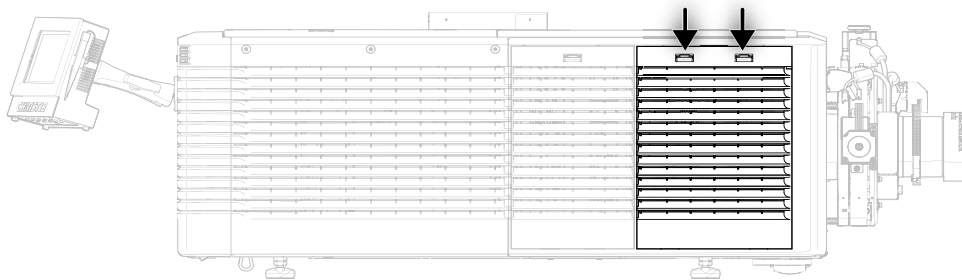

2. Lift up the cover enough for the bottom tabs to clear the frame and remove.
3. Slide the air filter out from behind the air filter cover and discard.
4. Insert the new air filter with the airflow indicator facing toward the projector.
This ensures proper particle filtration.
5. To complete the installation, align the bottom tabs and repeat these steps in reverse order.

Replace the liquid cooling air filter

This filter is located on front lamp-side of the projector, behind a small air filter cover. Check the condition of this filter monthly. Replace the liquid cooling air filter when refilling the liquid cooling module, or sooner when operating the projector in a dusty or dirty environment.

1. Release one tab on the air filter cover.
2. Rotate the top towards you and lift up to remove.
3. Slide the air filter out and discard.
4. Insert the new air filter with the airflow indicator facing toward the projector.
5. Install the air filter cover.

Replace the laminar airflow device filter

The laminar airflow device (LAD) filter is attached to the light engine assembly handle in the light engine compartment. Inspect the LAD filter every six months.

1. Shut down the projector.
2. Unlock and remove the front top cover.
3. Unlock and remove the light engine lid.
4. Remove the two screws securing the laminar airflow device filter (LAD) assembly to the bracket.
5. Pull out and replace the LAD filter.

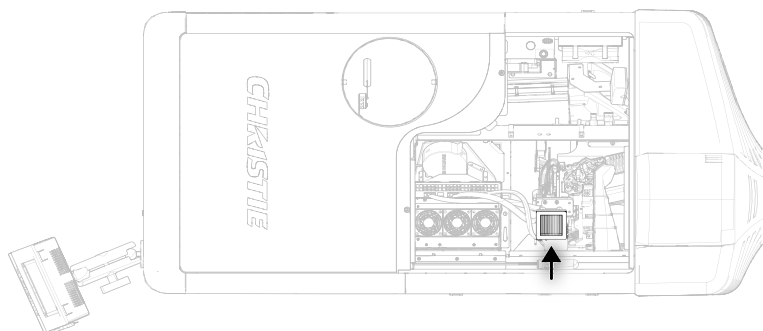

6. To reinstall, repeat these steps in reverse order.

For more details, see [Maintenance shutdown](#) on page 66.

Lamps



Danger! Failure to comply with the following results in death or serious injury.

- Lamp replacement must be performed by a qualified service technician only.
- EXPLOSION HAZARD. Wear authorized protective clothing (P/N: 598900-095) whenever the lamp door is open and when handling the lamp. Ensure those within the vicinity of the projector are also wearing protective safety clothing. Recommended protective clothing includes, but may not be limited to a polycarbonate face shield, protective gloves, and a quilted ballistic nylon jacket or a welder's jacket. Protective clothing recommendations are subject to change. Any local or federal specifications take precedence over Christie recommendations.
- Never twist or bend the quartz lamp body. Use the correct wattage lamp supplied by Christie.
- Never attempt to remove the lamp when it is hot. The lamp is under extremely high pressure when hot and may explode. Allow the lamp to cool completely before replacing.



Warning! Failure to comply with the following could result in death or serious injury.

- Possibly hazardous optical radiation emitted from this product. (Risk group 3).
- Thermal radiation emitted from this product may cause burns. (Risk group 3).

Always perform these steps before inspecting, removing, or installing any part of the lamp system:

1. Shut down the projector, disconnect from power, and let it cool.
2. Put on the protective clothing and face shield.
3. Use the key to open the lamp door and access the lamp compartment.

Do not lean, or place heavy objects on the open lamp door.

For more details, see [Maintenance shutdown](#) on page 66.

Adjust the yoke assembly

After installing the lamp, to ensure optimal operation of the lamp, check that the anode yoke is in the correct position for the lamp type:

Lamp	Type	Anode Yoke Position
2.0 kW	CDXL-20	Move the lamp cradle to the rear position, which is approximately 1" closer to the reflector.
3.0 kW	CDXL-20SP	
	CDXL-30	
	CDXL-30SP	
	CDXL-30SD	

The lamp extension nut is installed when using a CDXL-30SD lamp. Remove the nut if you are not using a CDXL-30SD lamp.

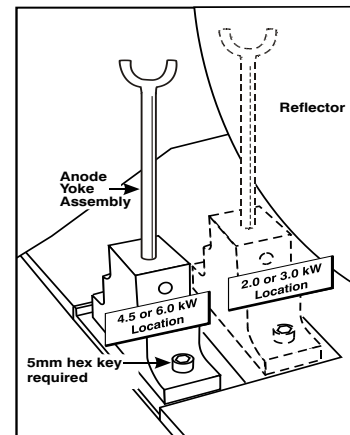

Inspect and clean the lamp



Danger! Failure to comply with the following results in death or serious injury. Always disconnect the projector from AC power and wear authorized protective safety gear.

- Check the contact surfaces of the anode (positive) and the cathode (negative) connections for cleanliness.
- Clean electrical contact surfaces regularly to prevent contact resistance from scorching connectors. Use an approved contact cleaner such as Sticklers Fiber Optic Cleaner.
- Verify that all electrical and lamp connections are secure.
- Use lint-free lab gloves.

Remove dust from the lamp

1. Brush most of the dust off with a camelhair brush or use a dust-free blower.
2. If some dust remains, leave it. Some dust is inevitable. Avoid unnecessary cleaning.

Remove fingerprints, smudges, or oil from the lamp

1. Brush most of the dust off with a camelhair brush or use a dust-free blower.

2. Fold a microfiber cloth and wipe the remaining dust particles off the lamp with the smooth portion of the cloth that has no folds or creases. Do not apply finger pressure. Instead, use the tension in the folded cloth to remove the dust.

Inspect and clean optics



Notice. Failure to comply with the following may result in property damage.

- A small amount of dust or dirt on the lens has minimal effect on image quality—to avoid the risk of scratching the lens, clean the lens only if absolutely required. The reflector and projection lens may be inspected and cleaned as per the following instructions. Any other optical maintenance should only be performed by qualified service technicians.
- Always wear powder free latex gloves when handling and cleaning projector optics.
- Only use solvents if dirt remains after dusting with compressed air.
- Do not reuse lens tissues. Use a clean tissue for each cleaning attempt.
- Handle optics by their edges.

Inspect these components periodically in a clean, dust-free environment using a high-intensity light source or flashlight. Clean them only when dust, dirt, oil, fingerprints, or other marks are obvious. Never touch an optical surface with bare hands. Always wear lint-free lab gloves.

The following tools are recommended for removing dust or grease:

- Powder free latex gloves
- Soft camel-hair brush
- Dust-free blower—filtered dry nitrogen blown through an anti-static nozzle
- Lint-free lens tissue, such as Lensx 90 tissue or Newport Optics cleaning tissue
- For the lens only—lens cleaning solution and microfiber cloth
- For the reflector only—Methanol
- Isopropyl Alcohol Reagent Grade (ACS) 99.9%
- Acetone Reagent Grade (ACS)
- Optical grade cotton swabs with wooden stems
- Sticklers Fiber Optic Cleaner (can be used on all optical components)
- A bright, portable illumination device such as an LED flashlight

Remove dust from the projection lens

1. Brush most of the dust off with a camel-hair brush or use a dust-free blower.
2. Fold a microfiber cloth and wipe the remaining dust particles off the lens with the smooth portion of the cloth that has no folds or creases. Do not apply finger pressure. Instead, use the tension in the folded cloth to remove the dust.
3. If significant dust remains on the lens surface, dampen a clean microfiber cloth with lens cleaning solution and wipe gently until clean.

Remove fingerprints, smudges, or oil from the projection lens



Do not use a cleaning solvent that contains ammonia. Avoid lens contact with Xylene and Ether.

1. Brush most of the dust off with a camelhair brush or use a dust-free blower.
2. Wrap a lens tissue around a swab and soak it in lens cleaning solution. The tissue should be damp but not dripping.
3. Gently wipe the surface using a figure eight motion.
4. Repeat until the blemish is removed. Clean the lens only if absolutely required.

Remove the projection lens

5. Close the shutter.
6. Attach a large lens cap to the front of the lens to avoid damage.
7. Release the lens locking lever (up position).
8. Pull the lens straight out and attach a small lens cap to the rear of the lens to avoid damage.

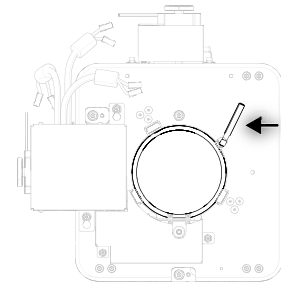

Warning! Failure to comply with the following could result in death or serious injury.
The lens tether must be installed for overhead installation.

For more details, see [Maintenance shutdown](#) on page 66.

Install the projection lens

1. Make sure the lens locking lever is in the up position.
2. If attached, remove the rear lens cap from the lens.
3. Slide the lens into the lens mount, aligning all connections.



Always install the lens with UP label in the top position. This assists in achieving consistent boresight alignment each time the lens is replaced.

4. Secure the lens with the lens locking lever (down position).
5. Calibrate the lens motors, as described below.

Calibrate the lens motors

If the lens motors are not calibrated properly, implications may include:

- Incorrect reporting of the lens motor position.
- Inability to use the full range of the lens motors.
- Lens motors traveling outside of the pre-defined keep-out area.
- Damage to the projector.

Calibrate the lens motors when any of the following conditions are met:

- After a lens change.
- After the projector is moved and/or jostled.
- After the lens motor IMCB has been replaced.

To calibrate the lens motors, on the touch panel controller, tap **Lens** > **Calibrate Lens Motors**.

Reset lens to home position

To reset the lens to the default home position, on the touch panel controller, tap **Lens** > **Reset to Home Position**.

Troubleshooting

This section provides information and procedures for resolving common projector issues. If a projector issue cannot be resolved, contact a Christie accredited service technician.

Projector does not power on

- Make sure the projector circuit breaker is set to the on position.
- Check the status LEDs on the rear corners of the projector for a fault condition. A flashing red LED indicates an alarm or warning preset with the projector and a problem that must be addressed.
- Use the touch panel controller (TPC) status menu to troubleshoot further.

Lamp does not ignite

- Check and correct all interlock failures.
- Verify that the lamp has been installed and connected properly. Verify the condition of the lamp and that is not blackened or otherwise damaged.
- Verify the number of hours the lamp has operated. A lamp nearing the end of its operational life should be replaced.

Lamp suddenly turns off

- Increase the lamp power.
- Review and correct all interlock failures.
- Ensure the TPC has no temperature or fan RPM warnings. If all fans are running normally and the air filters are not blocked, the ambient air temperature may exceed the maximum operating specification. If possible, reduce the ambient temperature.
- Ensure no heat sources are exhausting into the projectors intake, or move the projector to a cooler environment.

- Verify the number of hours the lamp has operated. A lamp nearing the end of its operational life should be replaced.
- Check for a cross-connected condition.

A cross-connection hazard can occur when installing multiple projectors at once. A fire hazard exists if a lamp power supply interlock cable is connected to a different projector than its lamp power cables.

Flicker, shadows or dimness

- Make sure the shutter is fully open.
- Verify that a LampLOC calibration is not already in progress.
- Perform a LampLOC calibration.
- Increase the lamp power. Lamps which are near end of service may not operate reliably at a lower power setting.

LampLOC not working

- If the **Auto LampLOC** option is not working, on the touch panel controller, tap **Menu > Lamp > LampLOC** and adjust the lamp position manually. Observe screen brightness by adjusting the X, Y and Z values or use a light meter to check for changes in brightness.
- Check that the flat part of the anode end of the lamp (if applicable) faces up in the anode yoke.

Touch panel controller is blank

- If the touch panel controller (TPC) display is blank, make sure the TPC communication harness is connected securely.

Blank screen, no display of image

- Make sure both lens caps have been removed from the projection lens.
- Make sure the lamp is on.
- Make sure that all power connections are good.
- Make sure the shutter is fully open.
- Make sure that any test pattern (other than a full black test pattern or test pattern = none) displays properly.

Cannot communicate with projector

- Make sure the computer and the projector are both connected to the network.
- Make sure that all input devices have the same subnet mask and unique IP addresses.

Inaccurate display colors

- Adjust the color, tint, color space, and color temperature settings of the input source.
- On the touch panel controller, tap **Menu > Configuration > Color Correction** and verify the settings are correct.

Display is not rectangular

- Verify the projector is level and the lens surface and screen are parallel to one another.
- Adjust the vertical offset of the lens mount.

Display has suddenly frozen

- If the source is frozen, restart the source device.
- If the source is not frozen, restart the projector.

Display is jittery or unstable

- Verify that the input device is connected properly. If the input device is not connected properly, the projector repeatedly attempts to display an image.
- The horizontal or vertical scan frequency of the input signal may be out of range for the projector.

For more details, see [Specification](#) on page 82

Incoming signal(s) problems

The Status tab > Signal group contains information about all the signals that the projector receives. A properly configured system shows the frequency and a status of Master or Locked for each input in the selected channel.

- If one or more of the signals are listed as No signal, verify that the source is properly configured and the cables are secure between the source and the projector.

- If one or more of the signals are listed as Inactive, either an incorrect channel has been selected or the cables are not plugged into the correct inputs.
- If one or more of the signals is listed as Unlocked or Out of phase, the source is not properly frame locked to the master signal. This usually occurs when two independent sources are not locked together. Verify the setup of the sources. If the sources are locked together, contact Christie Technical Support for help.

Touch panel controller or projector head problems on startup

Check the following to determine if the touch panel controller (TPC) or the projector head are experiencing problems on startup.

The projector has two sets of LEDs to help distinguish how far into the start-up process it is when a problem occurs.

For more details, see [LED expected behavior on power up](#) on page 53.

The Projector LEDs or the MCPU board power LED are not on

Solution 1

If AC power has been applied to the projector head, verify the power source.

Solution 2

If the AC power source is good and the AC power is applied to the projector head, check the LVPS and all the harnessing going to it inside the projector.

The MCPU board power LED is not on

If the AC power is applied to the projector head and the projector's LEDs turn on, the MCPU board or the ABP must be replaced. Replace the MCPU board first and if the problem is not resolved, replace the ABP.

- If replacing the MCPU board, indicate that the Power LED is non-functional.
- If replacing the ABP, indicate that power did not reach the MCPU board.

MCPU board power LED behavior

- Solid yellow—The MCPU board must be replaced. Indicate that the MCPU board failed to initialize.
- Blinking red—The MCPU board must be replaced. Indicate that the MCPU board failed to initiate the control FPGA.
- Blinking yellow/green—The MCPU board is running in recovery mode and needs a software upgrade followed by a AC cycle of the projector head.

Touch panel controller does not connect

If the projector LEDs display solid yellow and the touch panel controller (TPC) has power but does not connect, the projector head is fine. However, a problem could exist between the TPC and the MCPU board.

- Disconnect the corded harness to the TPC and reconnect it. You may need to replace the corded harness.
- Check for physical damage to the harness between the external TPC port and the ABP. Try changing the internal harness.

3D synchronization problems

A direct input 3D source requires a 3D external sync. The Status tab > Signal group has a 3D Sync item that displays “Valid 3D sync” if the incoming sync is correct.

- If the No 3D sync (using internal sync) message is displayed, no sync signal is detected on the 3D Sync In port.
- If the Invalid 3D sync (using internal sync) message is displayed, the sync signal is present but it is either not locked or is out of phase with the vsync of the master signal.

In both cases, the sync from the 3D source must be verified.

Left and right eye are reversed

Provided the Confirming Emitter setup was successfully performed, the 3D source in combination with the 3D external sync may be reversing the frames. To correct this, on the touch panel controller, tap **Main > 3D Settings > Invert Left/Right Eye**.

Frame multiplication applied to incoming video signals when not required

Frame multiplication is enabled when 3Dmode is on (auto). Disabling this setting prevents frame multiplication.

With 3D mode enabled, Mirage 4K35 projectors apply the following multiplication rules:

- Incoming ~48Hz => Outgoing ~144Hz (triple)
- Incoming ~50Hz => Outgoing ~150Hz (triple)
- Incoming ~60Hz => Outgoing ~120Hz (double)

For more details, refer to the TDM-3D Mode (Mirage 4K) section in the [Christie D4K and Mirage 4K Serial API Commands Technical Reference \(P/N: 020-101258-XX\)](#).

Run the projector interrogator

The interrogator captures diagnostic information Christie personnel uses to help diagnose and correct projector issues. If a projector issue cannot be resolved, Christie personnel may request an interrogator file from the projector.

Log files are compressed into a standard zip file.

1. On the touch panel controller, tap **Admin > Interrogator**.
2. Tap **Create File**.
3. Click **Continue**.
4. In the Choose destination directory dialog, navigate to the location where you want to store the log file.
5. Tap **Save**.

Save TPC log files

TPC log files can help you identify and correct issues with the touch panel controller. If a projector issue cannot be resolved, Christie personnel may request a TPC log file from the projector.

Log files are compressed into a standard zip file.

1. On the touch panel controller, tap **Admin > TPC Logs**.
2. Tap **Create File**.
3. In the Choose destination directory dialog, navigate to the location where you want to store the log file.
4. Tap **Save**.

Specification

This section provides detailed Mirage 4K25 specifications. Due to continuing research, specifications are subject to change without notice.

Display

Panel Resolution and Refresh Rate	
Pixel format (H x V square pixels)	4096 x 2160
Processing path	23.97 - 60Hz

Achievable Brightness (Measured at Screen Center)	
	Nominal
2.0 kW (CDXL-20)	10,000 lumens
2.0 kW (CDXL-20SP)	10,000 lumens
3.0 kW (CDXL-30)	18,000 lumens
3.0 kW (CDXL-30SD)	25,000 lumens
3.0 kW (CDXL-30SP)	19,000 lumens

Achievable Contrast Ratio	
450:1 ANSI, up to 2000:1 Full Frame ON/OFF	

Color and Grayscale Resolution	
Displayable colors	35.2 trillion
Grayscale resolution	45 bits total linear, 25 bits per RGB component

White Point	
Nominal white (full white, after calibration)	$y = 0.351 \pm 0.002$
	$x = 0.314 \pm 0.002$

Gamma

Nominal

2.2 ± 5%

Mirage signal connectivity

2D/ 3D	Input Configuration	3D Type	Input Format	Frame Rate (Hz)	Interface	Cards	Cables	RGB/		4:2:			
								4:4:4 8-bit	10-bit	2 8-bit	2 10-bit	4:2: 2 12-bit	4:2: 2 bit
3D	Four-Port	Direct	4K, QHD	120	DisplayPort 1.1a	4x TDPIC	4	X	X				
3D	Four-Port	Direct	4K, QHD	120	DVI (Dual)	4x DDIC	4	X					
3D	Four-Port	Dual- Input	4K, QHD	60	DisplayPort 1.1a	4x TDPIC	8	X	X		X	X	X
3D	Four-Port	Dual- Input	4K, QHD	60	HDMI 1.4a	4x THIC	8	X	X		X	X	X
3D	Two-Port	Dual- Input	4K, QHD	60	DisplayPort 1.1a	4x TDPIC	4	X	X				
3D	Two-Port	Dual- Input	4K, QHD	60	DVI (Dual)	4x DDIC	4	X					
3D	Four-Port	Dual- Input	4K, QHD	60	3G-SDI	4x 3GIC	8				X		
3D	Four-Port	Direct	4K, QHD	60	DisplayPort 1.1a	2x TDPIC	4	X	X		X	X	X
3D	Two-Port	Direct	4K, QHD	60	DisplayPort 1.1a	2x TDPIC	2	X	X				
3D	Four-Port	Direct	4K, QHD	60	HDMI 1.4a	2x THIC	4	X	X		X	X	X
3D	Four-Port	Direct	4K, QHD	60	3G-SDI	2x 3GIC	4				X	X	
3D	Two-Port	Direct	4K, QHD	60	DVI (Dual)	2x DDIC	2	X					
3D	Four-Port	Direct	4K, QHD	60	DVI (Single)	4x DDIC	4	X					
3D	Four-Port	Direct	4K, QHD	48, 50	DisplayPort 1.1a	2x TDPIC	4	X	X		X	X	X
3D	Two-Port	Direct	4K, QHD	48, 50	DisplayPort 1.1a	2x TDPIC	2	X	X				
3D	Four-Port	Direct	4K, QHD	48, 50	HDMI 1.4a	2x THIC	4	X	X		X	X	X

2D/ 3D	Input Configuration	3D Type	Input Format	Frame Rate (Hz)	Interface	Cards	Cables	RGB/ 4:4:4 8-bit	RGB/ 4:4:4 10-bit	RGB/ 4:4:4 12-bit	4:2: 2 8-bit	4:2: 2 10-bit	4:2: 2 12-bit
3D	Two-Port	Direct	4K, QHD	48, 50	DVI	2x DDIC	2	X					
3D	One-Port	Dual-Input	2K, HD	60	DisplayPort 1.1a	1x TDPIC	2	X	X		X	X	X
3D	One-Port	Dual-Input	2K, HD	60	HDMI 1.4a	1x THIC	2	X	X	X	X	X	X
3D	One-Port	Dual-Input	2K, HD	60	3G-SDI	1x 3GIC	2					X	
3D	One-Port	Dual-Input	2K, HD	60	DVI (Single)	2x DDIC	2	X					
3D	One-Port	Direct	2K, HD	120	DisplayPort 1.1a	1x TDPIC	1	X	X				
3D	One-Port	Direct	2K, HD	120	DVI (Dual)	1x DDIC	1	X					
3D	One-Port	Direct	2K, HD	60	DisplayPort 1.1a	1x TDPIC	1	X	X		X	X	X
3D	One-Port	Direct	2K, HD	60	HDMI 1.4a	1x THIC	1	X	X	X	X	X	X
3D	One-Port	Direct	2K, HD	60	3G-SDI	1x 3GIC	1					X	
3D	One-Port	Direct	2K, HD	60	DVI (Single)	1x DDIC	1	X					
3D	One-Port	Direct	2K, HD	48, 50	DisplayPort 1.1a	1x TDPIC	1	X	X		X	X	X
3D	One-Port	Direct	2K, HD	48, 50	HDMI 1.4a	1x THIC	1	X	X	X	X	X	X
3D	One-Port	Direct	2K, HD	48, 50	3G-SDI	1x 3GIC	1					X	
3D	One-Port	Direct	2K, HD	48, 50	DVI (Single)	1x DDIC	1	X					
2D	Four-Port		4K, QHD	120	DisplayPort 1.1a	4x TDPIC	4	X	X				
2D	Four-Port		4K, QHD	120	DVI (Dual)	4x DDIC	4	X					
2D	One-Port		2K, HD	120	DisplayPort 1.1a	1x TDPIC	1	X	X				
2D	One-Port		2K, HD	120	DVI (Dual)	1x DDIC	1	X					

<ul style="list-style-type: none">• 4K = 4096 x 2160	<ul style="list-style-type: none">• QHD = 3840 x 2160
<ul style="list-style-type: none">• 2K = 2048 x 1080	<ul style="list-style-type: none">• HD = 1920 x 1080

Optional Input cards

Input Card	Part Number	Additional Information
Dual 3G SD/HD-SDI	108-313101-02+	
Dual Link DVI	108-312101-02+	Analog signals are not supported for this input card; therefore VGA port and VGA to DVI converters are not supported.
Twin HDMI	108-311101-XX	
Twin DisplayPort	108-451101-XX	

To determine which SDI signal types are officially supported, see [Mirage signal connectivity](#) on page 84.

Control signal compatibility

Ethernet Port	
Interface	10Base-T/100Base-TX
Connector	Female RJ-45

USB	
Connector	Type B
Interface	USB to serial (bit rate identical to RS232)

3D Sync	
Connector	BNC Male
Interface	TTL inputs and outputs

RS422	
Connector	9-pin subminiature D, female
Bit rate	115,200 bps
Data format	1 start bit, 8 data bits, 1 stop bit, no parity

RS232 IN	
Connector	9-pin subminiature D, female
Bit rate	115,200 bps
Data format	1 start bit, 8 data bits, 1 stop bit, no parity

RS232 OUT	
Connector	9-pin subminiature D, male
Bit rate	115,200 bps
Data format	1 start bit, 8 data bits, 1 stop bit, no parity

Temperature sensor thresholds

The projector shutdowns within one minute of an error threshold being reached.

Location	Warning (°C)	Error (°C)	Remarks
Integrator rod	110	120	
Prism	60	70	
Air intake	44	49	
Lamp exhaust	85	95	
MCPU	70	95	
ABP	82	95	
HIP scaler	82	95	
HIP warp red	82	95	
HIP warp green	82	95	
HIP warp blue	82	95	
Formatter red	82	95	
DMD red	63	68	
Formatter green	82	95	
DMD green	63	68	
Formatter blue	82	95	
DMD blue	63	68	
Option card 1	80	95	
Option card 2	80	95	
Option card 3	80	95	
Option card 4	80	95	
EVB	70	95	
Lens MCB	75	95	v1.0x software only; removed in v1.1.0+ software
Lamp MCB	70	95	v1.0x software only; removed in v1.1.0+ software

Warning thresholds for fans

All fan warnings are set to ~75% of their normal operating speeds.

Location	Warning RPM
Light engine intake (fan 5)	3300
Light engine intake (fan 6)	3300
Light engine intake (fan 8)	3300
Formatter—green blower (fan 7)	3500
Laminar airflow device (fan 4)	5900
Electronics intake (fan 10)	5700
Electronics intake (fan 11)	5700
Electronics intake (fan 12)	5700
Image processor warp blower (fan 9)	2400
Electronics exhaust (fan 1)	3400
Electronics exhaust (fan 2)	3400
Liquid cooling radiator (fan 3)	1800
Image processor scaler (fan 13)	5100

Warning threshold for liquid cooling module

Location	Warning
Flow meter	0.2mL/min
Liquid cooling pump	180 RPM

Touch panel controller

TPC 650H	
Type of display	Color VGA TFT LCD, backlit
Display size	144.8 mm (5.7 inches) diagonal
Display resolution (H x V pixels)	640 x 480
Maximum dimensions (W x H x D)	195 mm x 148 mm x 58 mm
Integrated operating system	Microsoft Windows® XPe
Communication interface with projector	10/100/1000 BaseT Ethernet
Power requirement	0.71A maximum at 24VDC ± 10%
Interface connector	12-pin circular connector (push-pull)

Power requirements

AC Input	
Voltage range	200 - 240 VAC
Line frequency	50 - 60 Hz nominal
Inrush current	45 A maximum
Current consumption	23 A maximum (at 200 VAC)
Power consumption	4500 W maximum
Current rating of AC input	30 A maximum (specified wall breaker)

Lamp

Xenon Bubble Lamp	
Type	Xenon bubble
CDXL-20	1400W - 2000W
CDXL-20SP	1400W - 2000W
CDXL-30	2100W - 3000W
CDXL-30SP	2100W - 3000W

Average life	
CDXL-20	2400 hours
CDXL-20SP	3200 hours
CDXL-30	1500 hours
CDXL-30SP	1900 hours
Wait time between lamp strikes	2 minutes minimum

NOTE: Projectors typically force a 10 minute cool down period. Make sure not to re-strike the lamp any sooner than two minutes into this cool down period since hot re-strikes reduce lamp life.

Physical specifications

Overall size (L x W x H) (including lens mount, stack, and feet)	1298 x 648 x 483 (mm) 51.1 x 25.5 x 19.0 (inches)
---	--

Projector head weight

Without lens mount cover	124 kg (273 lbs)
Shipping (includes packaging)	156 kg (344 lbs)
Operating position	
Rotation about projection axis	± 15 degrees maximum
Tilt of projection axis from horizontal	± 15 degrees maximum

Regulatory

This product conforms to the following regulations related to product safety, environmental requirements and electromagnetic compatibility (EMC).

Safety

- CAN/CSA C22.2 No. 60950-1
- UL 60950-1
- IEC 60950-1
- EN60950-1

Approvals

This product shall conform to all relevant directives, standards, safety, health and environmental rules and regulations required for the product to be sold in: USA/Canada, EU, Norway, Australia/New Zealand, Kuwait, China, Korea, Japan, Mexico, Ukraine, Russia, South Africa, and Saudi Arabia international packaging recycling mark requirements:

- EU Directive (94/62/EC) on packaging and packaging waste;
- China packaging recycling mark standard (GB18455-2001).

Electro-magnetic compatibility

Emissions

FCC CFR47, Part 15, Subpart B, Class A - Unintentional Radiators
CISPR 22/EN 55022, Class A - Information Technology Equipment

Immunity

CISPR 24/EN55024: EMC Requirements—Information Technology Equipment

Environmental

EU Directive (2011/65/EU) on the restriction of the uses of certain hazardous substances (RoHS) in electrical and electronic equipment and the applicable official amendment(s)

EU Regulation (EC) No. 1907/2006 on the registration, evaluation, authorization and restriction of chemicals (REACH) and the applicable official amendment(s).

EU Directive (2012/19/EU) on waste and electrical and electronic equipment (WEEE) and the applicable official amendment(s)

China Ministry of Information Industry Order No.39 (02/2006) on the control of pollution caused by electronic information products, hazardous substances concentration limits (SJ/T11363-2006), and the applicable product marking requirements (SJ/T11364-2006)

Environment

Operating Environment	
Temperature	10 to 35°C (50 to 95°F)
Humidity (non-condensing)	20 to 80%
Altitude	0 to 3000 meters
Maximum ambient temperature	35°C
Non-Operating Environment	
Temperature	-25 to 65°C (-13 to 149°F)
Humidity (non-condensing)	0 to 95%

Accessories

Standard (Included with product)	
<ul style="list-style-type: none"> • Lens plug (required for shipping when lens is not installed to prevent contamination of critical optical components) 	
<ul style="list-style-type: none"> • Nylon safety strap with clip (required to secure projector to tabletop or optional rack mount) 	
<ul style="list-style-type: none"> • Touch panel controller (TPC) with interface cable 	<ul style="list-style-type: none"> • Shroud
<ul style="list-style-type: none"> • Light engine removal tool 	<ul style="list-style-type: none"> • Convergence tool
<ul style="list-style-type: none"> • Warranty card 	<ul style="list-style-type: none"> • Web registration form
<ul style="list-style-type: none"> • Low security keys 	

Lenses (sold separately)	
Description	Part Number
Lens 0.72:1	113-104106-XX
Lens 0.9:1	38-809071-XX

Lenses (sold separately)

Description	Part Number
Lens 1.13-1.31:1	129-104106-XX
Lens 1.63-1.63:1	129-105107-XX
Lens 1.63-2.17:1	129-106108-XX
Lens 1.98-2.71:1	129-107109-XX
Lens 3.0-4.3:1	129-108100-XX
Lens 3.89-5.43:1	129-109101-XX
Lens 5.0-7.69:1	129-110103-XX

Note: The lens throw values in the lens name may differ from the actual throw ratios. For details, see the 4K Lens Throw Technical Reference (P/N: 020-100904-XX).

Replacement Lamps (sold separately)

Description	Part Number
CDXL-20	003-000598-02
CDXL-20SP	003-004251-01
CDXL-30	003-000599-02
CDXL-30SD	003-001165-01
CDXL-30SP	003-004252-01

Replacement Air Filters (sold separately)

Description	Part Number
Light engine filter (five-pack)	003-001184-XX
Liquid cooling radiator filter	003-003082-XX
LAD filter (three-pack)	03-001982-51P

Other Accessories (sold separately)

Description	Part Number
Rack stand	108-282101-XX
Bracket foot lock used with optional rack stand	116-100101-XX
High-contrast Internal Aperture kit	38-813028-51
Service Manual	available online
Firmware Installation program	available online
Coolant propylene glycol	003-103148-XX
TPC remote cable	003-111169-XX
Heat extractor kit	38-814008-61



ASSYTECH DOCS Mirage 4K25

Corporate offices

USA – Cypress
ph: 714-236-8610

Canada – Kitchener
ph: 519-744-8005

Consultant offices

Italy
ph: +39 (0) 2 9902 1161

Worldwide offices

Australia
ph: +61 (0) 7 3624 4888

Brazil
ph: +55 (11) 2548 4753

China (Beijing)
ph: +86 10 6561 0240

China (Shanghai)
ph: +86 21 6278 7708

Eastern Europe and
Russian Federation
ph: +36 (0) 1 47 48 100

France
ph: +33 (0) 1 41 21 44 04

Germany
ph: +49 2161 664540

India
ph: +91 (080) 6708 9999

Japan (Tokyo)
ph: 81 3 3599 7481

Korea (Seoul)
ph: +82 2 702 1601

Republic of South Africa
ph: +27 (0)11 510 0094

Singapore
ph: +65 6877-8737

Spain
ph: + 34 91 633 9990

United Arab Emirates
ph: +971 4 3206688

United Kingdom
ph: +44 (0) 118 977 8000

