

JVC



D-ILA PROJECTORS

DLA-X9900BE
DLA-X7900BE/WE
DLA-X5900BE/WE

The "Golden Ticket" to High Dynamic Range



4K
e-shift5

D-ILA

HDR
High Dynamic Range



The overwhelming power and details of 4K quality.
Discover a totally unprecedented viewing experience.

4K
e-shift5

D-ILA

HDR
High Dynamic Range



DLA-X9900BE

4K-resolution D-ILA Projector

- Dynamic contrast ratio: 1,600,000:1 • Native contrast ratio: 160,000:1
- Brightness: 2,000 lm • Compatible with HDMI standard (4K60P 4:4:4) and HDCP 2.2



DLA-X7900BE/WE

4K-resolution D-ILA Projector

- Dynamic contrast ratio: 1,300,000:1 • Native contrast ratio: 130,000:1
- Brightness: 1,900 lm • Compatible with HDMI standard (4K60P 4:4:4) and HDCP 2.2 • Available in 2 colours (black and white)



DLA-X5900BE/WE

4K-resolution D-ILA Projector

- Dynamic contrast ratio: 400,000:1 • Native contrast ratio: 40,000:1
- Brightness: 1,800 lm • Compatible with HDMI standard (4K60P 4:4:4) and HDCP 2.2 • Available in 2 colours (black and white)



See the shower of light and details in pitch darkness

4K video full of reality is achieved through high brightness and ultimate dynamic range



[New 4K e-shift5 technology for improved definition]

JVC's e-shift technology, which shifts sub-frames by 0.5 pixels vertically and horizontally to achieve 4 times the pixel density of the original content, has evolved to meet the growing demand for 4K. Now e-shift5 technology employs completely new algorithms to realize a dramatic boost in diagonal detection precision, thus achieving even higher definition and improved picture quality.

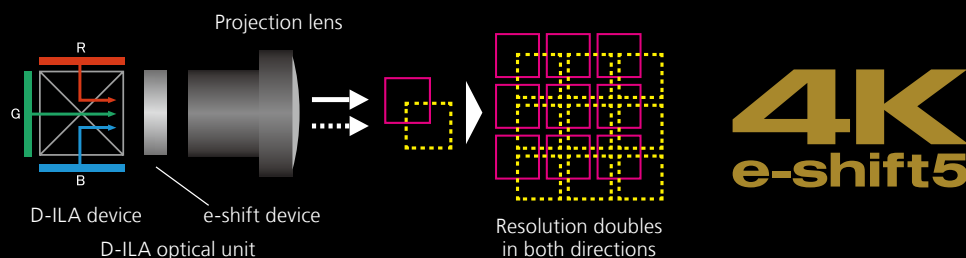

[Complies with the HDCP 2.2 standards to enable 18Gbps 4K signal input]

The projectors are capable of receiving full spec 4K signals including 4K/60P 4:4:4, 4K/60P 4:2:2/36-bit and 4K/24P 4:4:4/36-bit as the units comply with the latest HDMI standard with 18 Gbps transmission band-width compatibility for reproducing more vivid colours with more precise gradation. In order to be compatible with copyright-protected content such as OTT video services and the UHD Blu-ray discs, the projectors comply with the latest HDMI standard and HDCP 2.2.

[Improved compatibility with high-resolution HDR content]

Projectors require adjustment for screen size and environmental conditions to reproduce the PQ curve of the HDR10 standard. In addition to HDR Auto Picture mode, JVC D-ILA projectors offer several manual controls – including Picture Tone and Bright/Dark level gamma adjustment – so users can fine-tune the projected image to enhance their viewing experience. Additionally, the latest DLA-X9900BE and DLA-X7900BE/WE feature an all-new colour profile that is 20% brighter. Together with Intelligent Lens Aperture, which can be used with HDR10 content, this ensures the most dynamic HDR images ever. These models can also display the MaxCLL and MaxFALL mastering data*¹ available for HDR content on some UHD Blu-ray discs.

*1: May not be compatible with some content or players.

[High-quality video with Low Latency Mode]

D-ILA projectors feature an improved Low Latency Mode*² that ensures faster response with PC and game console content. In addition, when this mode is active high-bandwidth signals such as 4K with 10-bit or 12-bit colour depth can be processed without compression, resulting in high-quality video performance without any deterioration, regardless of source.



*2: The feature cannot be used with 3D playback mode or 3D Clear Motion Drive.

Smooth, vivid and high-definition. 4K quality as only D-ILA makes possible.

Technologies to realise D-ILA 4K images



[Exceptionally bright 2,000 lumens*³ to offer bright, high-resolution images]

The combination of 265W high-output NSH lamp and highly efficient optical engine on the new D-ILA projectors delivers a brightness of 2,000 lumens*³. What's more, smoother and more powerful pictures can be achieved through JVC's original D-ILA device with an even narrower gap between pixels for efficient use of light. Powerful, vivid and highly detailed 4K high-definition video can be enjoyed even in environments where it's hard to block out light, such as living rooms, that are not ideally suited for viewing high-definition videos.

*3: DLA-X9900BE



[High contrast ratio of D-ILA projectors delivers images with full of presence]

JVC's original D-ILA device combined with an optical engine equipped with a wire grid that complements the new high-output lamp results in high native contrast ratio of 160,000:1*⁴. Input signals are analysed with an original algorithm that is combined with Intelligent Lens Aperture, which automatically controls the black level of the image to achieve an ultimate dynamic contrast of 1,600,000:1*⁴. The synergetic effect based on the ultimate dynamic range stemming from high-brightness, delivers sensational 4K video full of reality.

*4: DLA-X9900BE

[Multiple Pixel Control]

D-ILA projectors feature original high-performance image processing technology, Multiple Pixel Control. Through adoption of a new analysis algorithm, the MPC is capable of more accurate diagonal-detection between frames for both full HD and full 4K resolution signals, delivering a thoroughly immersive high-definition 4K image. Compared to conventional band processing, MPC achieves the utter reality of 4K quality by detecting and processing images in a higher frequency range to achieve exceptional presence and bokeh.

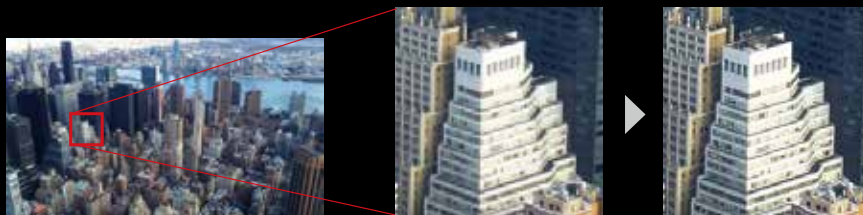

Original image

Conventional MPC technology

Multiple Pixel Control

[Exceptional motion image processing technologies for smooth video reproduction]

Two technologies are featured on the D-ILA projector – a moving image interpolation technology Clear Motion Drive that is compatible with 4K60P 4:4:4 signals and Motion Enhance technology that controls the driving performance of D-ILA devices by image characteristics. Owing to the two original technologies, the projector is capable of reducing ghosting or afterimage issues often found in fast-moving images to reproduce a crisp and smooth moving images.

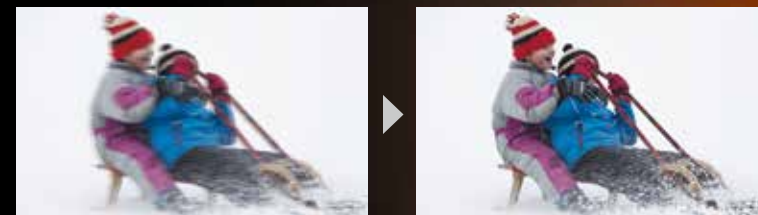

Clear Motion Drive OFF

Clear Motion Drive ON

Technologies to create images that match viewer preferences

JVC's advancing technologies and functions

[Original Real Colour Imaging Technology*5]

The colour reproduction ability on the original Real Colour Imaging Technology has improved with its capability to accurately grasp the colour information for precise reproduction. Also with the adoption of a new colour filter capable of covering the DCI*6 colour space, it is now possible to reproduce colours true to the original for exceptionally beautiful 4K images.

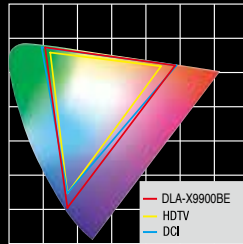

*5: DLA-X9900BE and DLA-X7900BE/WE.

*6: DCI stands for Digital Cinema Initiatives, a new standard for digital cinema.

[Colour Management System with 6-Axis Matrix]

A 6-axis matrix of red, green, blue, cyan, magenta, and yellow enables the precise adjustment of hue, saturation, and intensity. Only the colour being adjusted will be shown in colour while the others are grey-toned, making operation more intuitive.

[Auto-Calibration Function*7]

Using an optical sensor, precise calibration can be performed in just a few easy steps to match the changes in optical characteristics caused by the installation situation of the projector. Auto-Calibration optimises all essential elements found in the image, including colour balance, gamma characteristics, colour space, and colour tracking.



12-point manual gamma adjustment

Manual gamma adjustment, as requested by users, has been added to the calibration software. In addition to PC-based adjustments that are reflected to the image in real-time, adjustments using optical sensor can also be performed. It also features importing and exporting of gamma data.



*7: Exclusive JVC software installed on a PC connected to the projector via a LAN connection and optical sensor are required to set viewing configurations and auto calibration. Please visit the JVC website for the details.

[Screen Adjustment Modes]

The projector selects the best mode to match the screen being used for images with natural colour balance. The modes are compatible with the latest models offered by the world's major screen manufacturers.*8

*8: Please refer to JVC website for a comparison table of primary screens and adjustment modes



Screen Adjustment Modes OFF



Screen Adjustment Modes ON

[Pixel Adjust Function]

The Pixel Adjust function allows users to precisely correct colour deviation in 1/16-pixel increments. It is also capable of segmenting the entire screen into 121 points and adjusting them individually to realise clearer video without colour deviation. Two settings can be stored in the memory.

[Lens Memory Function]

This function stores ten*9 separate lens adjustments for zoom, shift and focus that can be easily recalled when needed. Memory settings can be switched between each setup via the remote controller.

*9: DLA-X9900BE and DLA-X7900BE/WE

Lens memory examples (when using CinemaScope screen)



Memory 1: Standard 16:9



Memory 2: CinemaScope Size



Memory 3: CinemaScope size with subtitles outside of the screen

[Industry Certified Projectors – THX 3D Display and ISF Certifications*10]

Accreditation with THX 3D Display Certification which was established to ensure that the certified projectors will precisely reproduce picture quality in home environments for both 2D and 3D content, just as the original filmmaker envisioned. Encompassing more than 400 laboratory tests to evaluate a projector's colour accuracy, cross-talk, viewing angles and video processing, this certification helps to guarantee high-definition quality.

*10: DLA-X9900BE and DLA-X7900BE/WE. Licensed with ISF (Imaging Science Foundation) C3 mode.



Feature Comparison

Model	DLA-X9900BE	DLA-X7900BE/WE	DLA-X5900BE/WE
4K e-shift5 Technology*11	□	□	□
18Gbps 4K signal input/HDCP 2.2	□	□	□
HDR10 compatibility	□	□	□
3D capability	□	□	□
Multiple Pixel Control	□	□	□
Clear Motion Drive	□	□	□
Motion Enhance	□	□	□
Low Latency Mode	□	□	□
Real Colour Imaging Technology	□	□	—
Colour Temperature (Xenon light-source colour)	□	□	—
Picture Tone	□	□	□
Pixel Adjust	□ (by 1/16-pixel increment, 2 memories)	□ (by 1/16-pixel increment, 2 memories)	□ (by 1/16-pixel increment, 2 memories)
Lens Memory	□ (10 memories)	□ (10 memories)	□ (5 memories)
Screen Adjustment Mode	□	□	□
Auto Calibration*12	□	□	□
12-point manual gamma adjustment*13	□	□	□
Picture Data In/Out*13	□	□	□
IMaxCLL & MaxFALL Mastering Data display	□	□	□
THX 3D Display Certification	□	□	—
ISF C3 mode	□	□	—

*11: This function cannot be used while projecting in 3D mode. *12: Requires a commercially available optical sensor and dedicated software as well as PC and LAN cables. *13: Requires dedicated software as well as PC and LAN cables.

[Even brighter and high-quality 3D images of D-ILA]

In addition to JVC's original Frame Addressing method to reproduce 3D images with vivid colours, the optical engine featuring a set of new D-ILA devices is capable of achieving more brightness. Furthermore, 3D image adjustment functions such as Crosstalk Cancelling are featured to offer the kind of realistic and exciting 3D images that only D-ILA can provide.

Notes about viewing 3D video content

- The optional 3D Synchro Emitter and 3D glasses are required to view 3D images from the D-ILA projectors. 3D video software (3D media or output of 3D broadcasts) and a 3D-compatible video player are also required.
- Perception of 3D images will vary with individual viewers.
- Stop viewing 3D images immediately if any discomfort such as headaches, dizziness, eye fatigue, etc. occurs.
- Viewing of 3D images by children under the age of five is not recommended.
- Read the Safety Precautions and the User Manual carefully before viewing any 3D source.

Optional Accessories



Replacement Lamp
PK-L2615U



RF (radio frequency) 3D Glasses
PK-AG3



RF (radio frequency) 3D Synchro Emitter
PK-EM2

Projection Distance Chart

Screen diagonal (inch)	Display size (16:9)		Projection distance	
	W (mm)	H (mm)	Wide (m)	Tele (m)
60	1,328	747	1.78	3.66
70	1,549	872	2.09	4.28
80	1,771	996	2.40	4.89
90	1,992	1,121	2.70	5.51
100	2,214	1,245	3.01	6.13
110	2,435	1,370	3.31	6.75
120	2,656	1,494	3.62	7.36
130	2,878	1,619	3.92	7.98
140	3,099	1,743	4.23	8.60
150	3,320	1,868	4.53	9.22
160	3,542	1,992	4.84	9.84
170	3,763	2,117	5.14	10.45
180	3,984	2,241	5.45	11.07
190	4,206	2,366	5.75	11.68
200	4,427	2,490	6.06	12.30

*Projection distances are design specifications, so there is $\pm 5\%$ variation.

Specifications

	DLA-X9900BE	DLA-X7900BE/WE	DLA-X5900BE/WE
Device	0.7 inch Full HD D-ILA (1920x1080) x3		
4K e-shift5 Technology	Yes		
Resolution	3840 x 2160 ^{*1}		
Lens	x2 Zoom & Focus: Motorised; f=21.4-42.8mm / F3.2-4		
Lens Shift	$\pm 80\%$ Vertical and $\pm 34\%$ Horizontal (motorised)		
Lens Cover	Yes	Yes	—
Projection Display Size	60 inch – 200 inch (diagonal)		
Light Source Lamp	NSH 265W (lamp life: approx. 4,500 hours when the lamp is in Low mode)		
Brightness	2,000 lm	1,900 lm	1,800 lm
Contrast Ratio	Dynamic	1,600,000:1	1,300,000:1
	Native	160,000:1	130,000:1
Input Terminal	HDMI	2 (3D/Deep Colour/HDCP2.2)	
	Trigger	1 (Mini jack, DC12V/100mA)	
Output Terminal	3D Sync	1 (Mini DIN 3pin)	
	RS-232C	1 (D-sub 9pin)	
Control Terminals	LAN (RJ-45)	1	

	DLA-X9900BE	DLA-X7900BE/WE	DLA-X5900BE/WE
Video Input Signal Format (Digital)	480p, 576p, 720p 60/50, 1080i 60/50, 1080p 60/50/24, 3840 x 2160p 60/50/30/25/24, 4096 x 2160p ^{*2} 60/50/30/25/24		
PC Input Signal Format (HDMI)	VGA/SVGA/XGA/WXGA/WXGA+/SXGA/WSXGA+		
3D Format	Frame Packing	720p 60/50, 1080p 24	
	Side-by-Side (half)	720p 60/50, 1080p 60/50/24, 1080i 60/50	
	Top & Bottom	720p 60/50, 1080p/24	
Power Consumption	380W (Normal standby: 1.5W, Eco-mode standby: 0.4W)		
Fan Noise	21dB (When the lamp is in Low mode)		
Power Requirement	AC110V-240V, 50/60Hz		
Dimensions (W x H x D)	455 x 179 x 472 mm		
Weight (net)	15.6kg	15.6kg	15.4kg

*1 Resolution is 1920x1080 at 3D mode.

*2 When the video input signal is at 4096 x 2160p, data above 3,840 is not displayed equally on the left and right.

Connectors

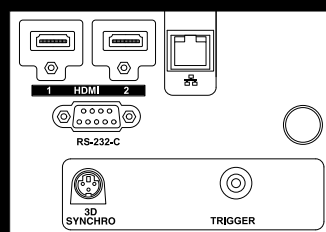

External Dimensions (unit: mm)

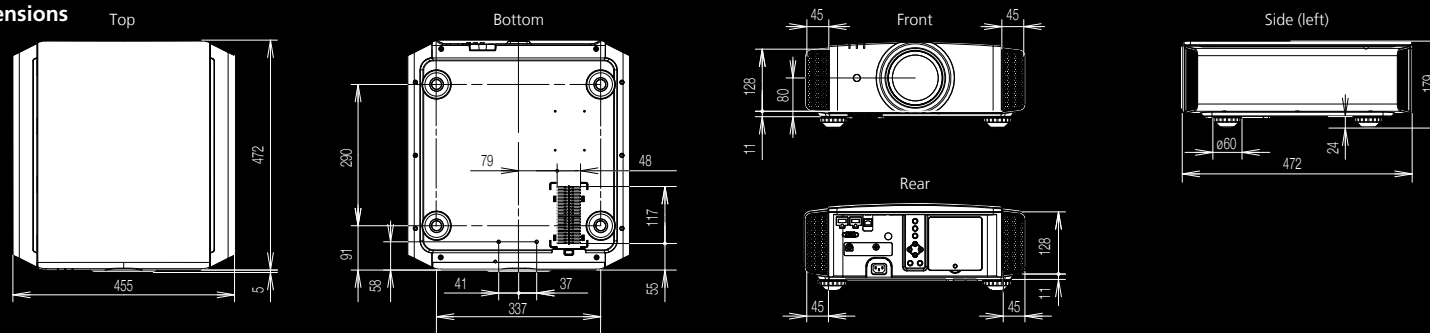

• D-ILA is a registered trademark of JVC KENWOOD Corporation. • THX and THX logo are trademarks of THX Ltd., which may be registered in some jurisdictions. • ISF is a registered trademark of Imaging Science Foundation, Inc. • HDMI, the HDMI logo and High-Definition Multimedia Interface are registered trademarks of HDMI Licensing LLC. • All other brand or product names may be trademarks and/or registered trademarks of their respective owners. • Please be aware that, because the D-ILA device is manufactured using highly advanced technologies, 0.01% or fewer of the pixels may be non-performing (always on or off). • The projector is equipped with an ultra-high pressure mercury lamp, which may break, emitting a loud noise, when it is subjected to shock or after it has been used for some length of time. • Please note that, depending on how the projector is used, there can be considerable difference between individual lamps regarding how many hours they will operate before requiring replacement. • An additional payment is required for installation of the projector or a new lamp, if necessary. • All pictures on this brochure are simulated. • Design and specifications are subject to change without notice. • Any rights not expressly granted herein are reserved.

Copyright © 2017, JVC KENWOOD Corporation. All Rights Reserved.

ProSelecta

View :: Compare :: Select - www.ProSelecta.com