

**JVC**  
PROFESSIONAL

D-ILA™ PROJECTOR  
**DLA-G20**

**SXGA**

**2000 ANSIS  
lumens**



# A Professional Data Projector

— True S-XGA D-ILA™ Projector with 2000 ANSI Lumens, Plus Full Range of Pro-Standard Features —

Now there's a better way to equip your boardroom, auditorium, training center, or meeting facility with the latest multimedia display capability — the DLA-G20 Data Projector from JVC. Combining true S-XGA resolution with a top-of-its-class brightness level of 2000 ANSI lumens and an ultra-high 350:1 contrast ratio, the DLA-G20 delivers exceptional image reproduction quality in any setting. Flexible installation configurations and a simplified setup procedure make this new-style projector versatile enough to satisfy any professional requirement.

## Ultra-High Brightness 2000 ANSI Lumens & Extra-High 350:1 Contrast Ratio

Incorporating a high-power Xenon lamp, the DLA-G20 boasts a top-of-its-class brightness level of **2000 ANSI**

**lumens**. In combination with the extra-high **contrast ratio of 350:1**, this ensures that projected images are clear and bright even under bright lighting conditions. The higher contrast brings out the tiniest details even in dark

portions of the picture while the Xenon lamp assures "true" color and clarity. The result is projection images with truly exceptional quality. Clear details, crisp edges, realistic color, and true black reproduction make for images comparable to what you'd get from the very best high-end CRT projectors.

## Designed for Professional Use

Specifically designed to satisfy the demanding requirements of professional applications, the DLA-G20 is equipped with two computer inputs for seamless integration into pre-installed cabling setups. Input channel settings can be set independently for each of the computer inputs (up to 10 user-preset channel settings available) and a wide range of scanning frequencies are provided to enable this high-performance projector to accommodate most standard input devices.



# for the Next Millennium

D-ILA™ projector image (simulated)



## Innovative Technologies for Superior Image Quality

The Adaptive DPC (Digital Pixel Conversion) circuitry optimizes picture quality regardless of the input signal resolution to ensure smooth, clear images. A 10-bit Digital Gamma Correction circuitry facilitates accurate gray scale and color reproduction.



Conventional projector image (simulated)

## D-ILA™ Device for Next-Generation Image Reproduction

Utilizing a high-density reflective LCD with a homeotropic structure in which the LCD elements are aligned vertically, the D-ILA™ (Direct Drive Image Light Amplifier) device produces extra-bright, high-resolution, high-contrast images ideal for big-screen projection applications.

## Workstation-Quality True S-XGA Resolution

The D-ILA™ projector can project extra-high resolution images of up to 1,365 x 1,024 pixels. That means it can easily handle even the super-sharp clarity of an S-XGA (1,280 x 1,024 pixels) image without the scaling or loss of quality that normally occurs when projecting the high-resolution computer graphics and CAD images produced by today's cutting-edge workstations and laboratories.

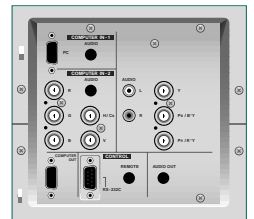

Full signal input capability

Even at the corners of the projected image, the small text, characters, icons and cursors typical of a computer display, as well as animated computer graphics, are all clearly legible.

## Application Example

Clear and crisp projection images available even in a bright, spacious site such as an auditorium.





## Major Specifications

● <b>Image Device:</b>	3 D-ILA™ (0.9 inches diagonal)
● <b>Projection Lens:</b>	2 : 1 – 3 : 1 (Throw distance : Screen size) Powered Zoom, 50% off-axis
● <b>Brightness:</b>	2,000 ANSI lumens
● <b>Resolution:</b>	1,365 x 1,024 pixels full coverage of S-XGA (1,280 x 1,024 ) graphics (S-XGA, XGA, S-VGA, VGA)
● <b>Contrast Ratio:</b>	More than 350 : 1
● <b>Color Reproduction:</b>	16.7 million colors
● <b>Scan Frequency:</b>	
Horizontal:	15 – 82 kHz
Vertical:	50 – 78 Hz
● <b>Input:</b>	Analog RGB x 2 (D-Sub (female) x 1, R,G,B,H,V x 1) Component x 1 (Y/R-Y/B-Y, Y/ P <sub>b</sub> / P <sub>r</sub> for HDTV)
● <b>Output</b>	
PC Monitor:	D-sub (female)
Audio:	Stereo
● <b>Throw Distance:</b>	2.5 m – 20 m (8.2 ft – 65.6 ft)
● <b>Screen Size:</b>	
Wide	1,778 mm – 13,233mm (70" – 521") (diagonally)
Tele	1,066 mm – 8,636 mm (42" – 340") (diagonally)
● <b>Lamp:</b>	550 watts, Xenon
● <b>Audio:</b>	Built-in stereo speakers (1 W + 1 W stereo)
● <b>Input Power:</b>	200 – 240 V, 50/60 Hz AC
● <b>Power Consumption:</b>	850 W
● <b>Dimensions (WxHxD):</b>	505 x 264 x 388 mm (20" x 10.4" x 15.3") excluding lens
● <b>Weight:</b>	17.3 kg (38.1 lbs)
● <b>Provided Accessories:</b>	AC cable, Wireless (infrared) remote control, PC connection cable (D-sub 15-pin male – D-sub 15-pin male), Adapter for Macintosh, AV cable, Audio cable, BNC-RCA adapter, Lens cap, Operation manual, Battery for remote control unit x 2

## Dimensions

Unit: mm (Inches)

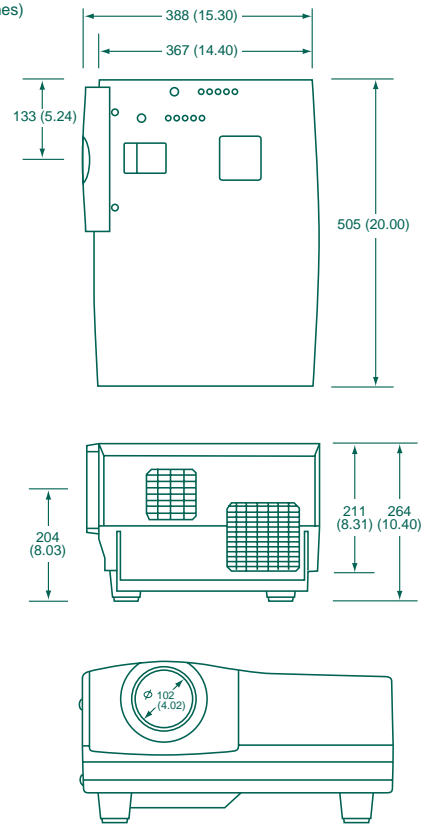

## Other Features

- Auto-alignment function for automatic adjustment of tracking, phase and position
- Up-down/left-right inversion
- Selectable color temperature (High/Mid/Low)
- Selectable background color (when no signal is input)
- On-screen menu (6-language selectable)
- Resizing function for full-screen projection of XGA/S-VGA/VGA images
- 1000 hours of lamp life
- Lamp life "warning" indicator
- Lamp "sleep" function — in the absence of any signal for a preset time (10 min., 20 min., 30 min. or 60 min. selectable), the lamp is automatically shut off for safety and power saving



Provided remote control

## DLA-G20 Throw Distance vs. Screen Size

(Offset projection angle:50%)

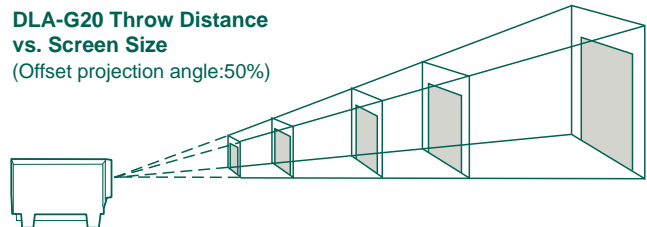

Throw Distance	(m)	4.13	5.86	8.75	11.63	17.40	
	(ft)	13.55	19.23	28.71	38.16	57.09	
Screen Size	Tele	(m)	1.42	2.03	3.05	4.06	6.10
	(Width)	(ft)	4.66	6.66	10.01	13.32	20.01
(Diagonally)	(inches)	70	100	150	200	300	
	Wide	(m)	2.15	3.18	4.16	6.14	9.22
	(ft)	7.05	10.43	15.12	20.14	30.25	
(Diagonally)	(inches)	106	151	227	302	454	

D-ILA is a trademark of Victor Company of Japan, Limited.

Design and specifications subject to change without notice.

Copyright © 1999, Victor Company of Japan, Limited (JVC). All Rights Reserved.

# JVC

DISTRIBUTED BY

# ProSelecta

View :: Compare :: Select - [www.ProSelecta.com](http://www.ProSelecta.com)

Printed in Japan  
PCUV-1299 (EU)